

ROBA[®]-ES

Backlash-free flexible shaft coupling

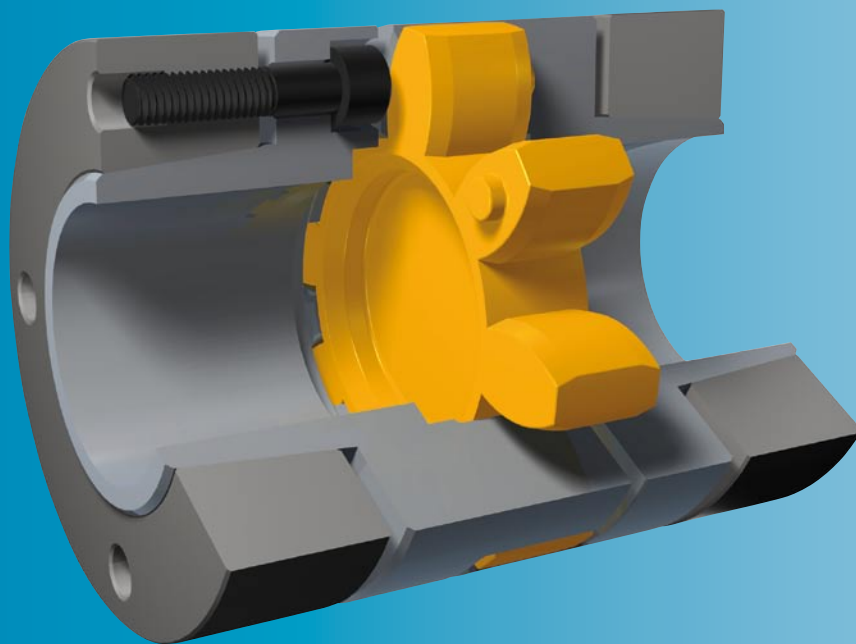

www.mayr.de

- *Simple plug-in installation*
- *Vibration-damping function*
- *Maintenance-free*

K.940.V07.GB

mayr[®]
your reliable partner

ROBA®-ES

for smooth running in vibration-critical drive systems

A flexible coupling in high-precision servo axes?

This concept is not a contradiction in terms, as the ROBA®-ES coupling convinces customers even in critical applications with backlash-free torque transmission, ideal rigidity and optimum vibration damping.

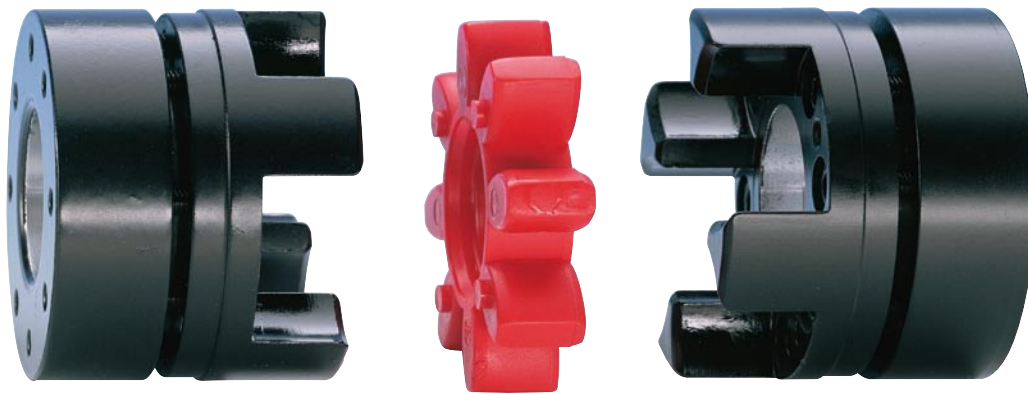

ROBA®-ES, the alternative to torsionally rigid shaft couplings.

- ❑ Backlash-free torque transmission due to pre-tensioned star-shaped elastomer element through which hardness, rigidity and damping behaviour can be varied.
- ❑ Compensation of radial, axial and angular shaft misalignment.
- ❑ Simple plug-in installation, maintenance-free function, agent resistance and temperature resistance guarantee highest operational safety.

ROBA®-ES - flexible and backlash-free smartflex® - torsionally rigid and backlash-free

Backlash is the angular tolerance between the input and the output, also known as torsional backlash. Many conventional flexible couplings are subject to backlash due to their construction type.

The mayr®-couplings ROBA®-ES, smartflex® and ROBA®-DS Type series transmit the torque backlash-free.

The couplings differ in damping behaviour and torsional rigidity:

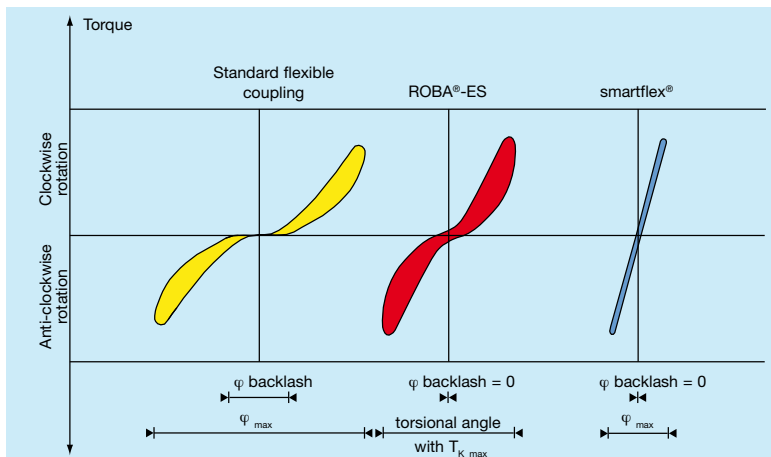

- ❑ The ROBA®-ES is torsionally rigid and can damp vibrations to a small extent. Its torsional rigidity is 2 to 4 times higher than a toothed belt drive.

- ❑ The smartflex® and ROBA®-DS are torsionally rigid all-metal couplings. They feature the smallest torsional angle at maximum torque. Due to the transmission element design in steel, they have no damping characteristics.



ROBA®-ES couplings are also available in ATEX design according to the directive 94/9 EC (ATEX 95).

Elastomeric Elements Page 4 ▷

Nominal torques	4 to 1040 Nm
Max. axial displacement	2,6 mm
Max. radial misalignment	0,25 mm
Max. angular misalignment	1,3°

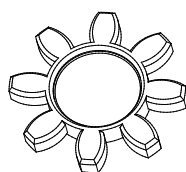

Temperature Influence	Page 4 ▷
Agent Resistance	Page 4 ▷
Torques	Page 5 ▷
Perm. Misalignment Values	Page 5 ▷
Spring Rigidity	Page 5 ▷

ROBA®-ES with keyways Type 940._22._ Page 6 ▷

Nominal torques	4 to 1040 Nm
Bores	6 to 80 mm
Max. axial displacement	2,6 mm
Max. radial misalignment	0,25 mm
Max. angular misalignment	1,3°

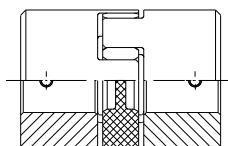

Technical Data	Page 6 ▷
Dimensions	Page 6 ▷
Order Example	Page 6 ▷

ROBA®-ES with clamping hubs Type 940._00._ Page 7 ▷

Nominal torques	2,5 to 1040 Nm
Bores	6 to 80 mm
Max. axial displacement	2,6 mm
Max. radial misalignment	0,25 mm
Max. angular misalignment	1,3°

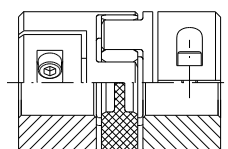

Technical Data	Page 7 ▷
Dimensions	Page 7 ▷
Order Example	Page 7 ▷

ROBA®-ES with aluminium shrink disk hubs Type 940._11.A Page 8 ▷

Nominal torques	7 to 617 Nm
Bores	6 to 45 mm
Max. axial displacement	1,8 mm
Max. radial misalignment	0,2 mm
Max. angular misalignment	1,3°

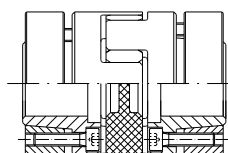

Technical Data	Page 8 ▷
Dimensions	Page 8 ▷
Order Example	Page 8 ▷

ROBA®-ES with steel shrink disk hubs Types 940._11.P and 940._11.F Page 9 ▷

Nominal torques	7 to 1040 Nm
Bores	6 to 75 mm
Max. axial displacement	2,6 mm
Max. radial misalignment	0,25 mm
Max. angular misalignment	1,3°

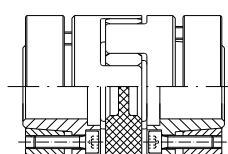

Technical Data	Page 9 ▷
Dimensions	Page 9 ▷
Order Example	Page 9 ▷

Frictionally-locking transmittable torques on clamping and shrink disk hubs Page 10 ▷

Technical Explanations Page 12 ▷

Installation Guidelines and Examples Page 13 ▷

Coupling Dimensioning Page 14 ▷

Elastomeric Elements

The elastomeric elements are the central element of the ROBA®-ES-coupling. They define the application range as well as the shaft connection behaviour via the permitted torque, rigidity, damping and misalignment values.

By using a unique polyurethane material and a special injection procedure, it is possible to achieve a high dimensional accuracy and evenness in the teeth of the elastomeric element.

The elastomeric elements are available in different shore hardnesses.

The teeth of the elastomeric element are chamfered at the sides. This makes blind installation easier.



Elastomeric element hardness [Shore]	Colour	Permitted temperature range	
		Permanent temperature	Temporary max. temperature
80 Sh A	Blue	-50 to +80 °C	-60 to +120 °C
92 Sh A	Yellow	-40 to +90 °C	-50 to +120 °C
98 Sh A	Red	-30 to +90 °C	-40 to +120 °C
64 Sh D	Green	-30 to +100 °C	-40 to +140 °C

Temperature Influence

The ambient temperatures present during operation have a considerable effect on the dimensioning of a ROBA®-ES-coupling (see Dimensioning page 14).

Dimensioning

The characteristics of ROBA®-ES couplings can be greatly varied by using different elastomeric elements. Due to different damping characteristics and the non-linear rigidity of the elastomer, this element also offers more parameters than the steel shaft connection, which should be taken into account on selection.

We therefore recommend careful, thorough coupling dimensioning (see Dimensioning page 14).

Agent Resistance

The elastomeric elements are very resistant against:

- pure mineral oils (lubricating oils)
- and anhydrous greases.

They have a similar resistance against fuels such as

- regular-grade petroleum
- diesel oil
- kerosene.

Damage may occur after longer exposure to

- alcohols or
- aromatic fuels (super/four star petrol).

The elastomeric element material used is resistant to hydrolysis. In contrast to other polyurethane materials, water (including seawater) causes, even after years of exposure, no particular changes to the mechanical characteristics. Hot water, however, reduces the mechanical strength.

For information on contact with special agents or radiation, please contact the manufacturers.

Please Observe:

According to German notation, decimal points in this document are represented with a comma (e.g. 0,5 instead of 0.5).

We reserve the right to make dimensional and constructional alterations.

Torques

Size	Torque Type 940.____ ¹⁾							
	Elast. element hardness 80 Sh A (blue)		Elast. element hardness 92 Sh A (yellow)		Elast. element hardness 98 Sh A (red)		Elast. element hardness 64 Sh D (green)	
	T _{KN} ²⁾ [Nm]	T _{K max} [Nm]	T _{KN} ²⁾ [Nm]	T _{K max} [Nm]	T _{KN} ²⁾ [Nm]	T _{K max} [Nm]	T _{KN} ²⁾ [Nm]	T _{K max} [Nm]
14	4	8	8	16	13	26	16	32
19	5	10	10	20	17	34	21	42
24	17	34	35	70	60	120	75	150
28	46	92	95	190	160	320	200	400
38	-	-	190	380	325	650	405	810
42	-	-	265	530	450	900	560	1120
48	-	-	310	620	525	1050	655	1310
55	-	-	410	820	685	1370	825	1650
65	-	-	900	1800	1040	2080	-	-
Only available on P-design (page 9)								
14-32	4	8	8	16	13	26	16	32
19-37,5	4	8	8	16	14	28	17	34
24-50	12	24	25	50	43	86	54	108

1) The permitted max. torque for Types 940.00. and 940.11. is dependent on bore diameter d3/d4, see Tables 1 to 4, pages 10 and 11.
2) For permitted alternating torques, see Coupling Dimensioning page 14.

Permitted Misalignment Values

Size	Shaft misalignments								
	Axial ΔK _a 80/92/98 Sh A 64 Sh D	Radial				Angular			
	ΔK _r 80 Sh A	ΔK _r 92 Sh A	ΔK _r 98 Sh A	ΔK _r 64 Sh D	α 80 Sh A	α 92 Sh A	α 98 Sh A	α 64 Sh D	
[mm]	[mm]	[mm]	[mm]	[mm]	[mm]	[mm]	[mm]	[mm]	
14	1,0	0,21	0,15	0,09	0,06	1,1	1,0	0,9	0,8
19	1,2	0,15	0,1	0,06	0,04	1,1	1,0	0,9	0,8
24	1,4	0,18	0,14	0,1	0,07	1,1	1,0	0,9	0,8
28	1,5	0,2	0,15	0,11	0,08	1,3	1,0	0,9	0,8
38	1,8	-	0,17	0,12	0,09	-	1,0	0,9	0,8
42	2,0	-	0,19	0,14	0,1	-	1,0	0,9	0,8
48	2,1	-	0,21	0,16	0,11	-	1,0	0,9	0,8
55	2,2	-	0,24	0,17	0,12	-	1,0	0,9	0,8
65	2,6	-	0,25	0,18	-	-	1,0	0,9	-
Only available on P-design (page 9)									
14-32	1,0	0,21	0,15	0,09	0,06	1,1	1,0	0,9	0,8
19-37,5	1,2	0,15	0,1	0,06	0,04	1,1	1,0	0,9	0,8
24-50	1,4	0,18	0,14	0,1	0,07	1,1	1,0	0,9	0,8

Spring Rigidity

Size	Static torsional spring rigidity				Dynamic torsional spring rigidity				Static radial spring rigidity			
	C _{T stat.} 80 Sh A	C _{T stat.} 92 Sh A	C _{T stat.} 98 Sh A	C _{T stat.} 64 Sh D	C _{T dyn.} 80 Sh A	C _{T dyn.} 92 Sh A	C _{T dyn.} 98 Sh A	C _{T dyn.} 64 Sh D	C _r 80 Sh A	C _r 92 Sh A	C _r 98 Sh A	C _r 64 Sh D
	[Nm/rad.]	[Nm/rad.]	[Nm/rad.]	[Nm/rad.]	[Nm/rad.]	[Nm/rad.]	[Nm/rad.]	[Nm/rad.]	[N/mm]	[N/mm]	[N/mm]	[N/mm]
14	50	80	120	230	120	240	300	730	180	300	470	960
19	350	820	900	1400	1050	1800	2200	4200	700	1200	2100	2700
24	820	2300	3700	4500	1300	4800	7600	10800	800	1900	2800	4200
28	1300	3800	4200	7000	2200	6800	10100	17200	950	2100	3500	4900
38	-	5600	7400	9000	-	11900	19900	30500	-	2900	4800	5600
42	-	9800	13800	15000	-	20500	31100	64900	-	4100	5400	6900
48	-	12000	15100	28500	-	22800	44900	102800	-	4500	6200	8200
55	AVAILABLE ON REQUEST				AVAILABLE ON REQUEST				AVAILABLE ON REQUEST			
65	AVAILABLE ON REQUEST				AVAILABLE ON REQUEST				AVAILABLE ON REQUEST			
Only available on P-design (page 9)												
14-32	50	80	120	230	120	240	300	730	180	300	470	960
19-37,5	280	660	720	1120	840	1440	1760	3360	560	960	1680	2160
24-50	600	1700	2700	3300	1000	3600	5700	8100	600	1500	2100	3200

ROBA®-ES with keyways Type 940. 22.

Sizes 14 to 65

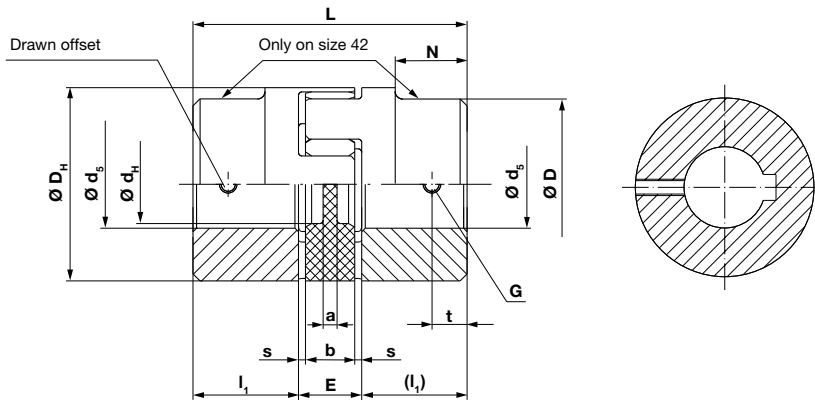

ROBA®-ES couplings are delivered as un-bored hub design (further processing to be carried out customer-side) or with a finish bore and keyway JS9 (DIN 6885/1). An adjusting screw is located in the hub for axial securement, which is offset by 180° to the keyway (see Fig. right).

Up to size 38, the hubs are made of aluminium. From size 42, they are made of steel.

Conventional bores can be delivered from stock.

Fig. 1: Type 940. 22.

Technical Data and Bores			Size ¹⁾								
			14	19	24	28	38	42	48	55	65
Minimum hub bore ²⁾	d _{5 min}	[mm]	6	6	8	10	12	14	20	20	38
Maximum hub bore ²⁾	d _{5 max}	[mm]	15	24	28	38	45	55	60	70	80
Maximum speed	n _{max}	[rpm]	19000	14000	10600	8500	7100	6000	5600	5000	4600
Mass moments of inertia	J	[10 ⁻⁶ kgm ²]	2,8	20,4	50,8	200,3	400,6	2246	3786	8546	16043
Weight		[kg]	0,020	0,066	0,132	0,253	0,455	1,85	2,52	4,14	5,96

Dimensions	Size ²⁾								
	14	19	24	28	38	42	48	55	65
a	2	4	4	5	5	5	5	9	8
b	10	12	14	15	18	20	21	22	26
D	-	-	-	-	-	75	-	-	-
D _h	30	40	55	65	80	95	105	120	135
d _h	10,5	18	27	30	38	46	51	60	68
E	13	16	18	20	24	26	28	30	35
G	M4	M5	M5	M6	M8	M8	M8	M10	M10
L	35	66	78	90	114	126	140	160	185
l ₁	11	25	30	35	45	50	56	65	75
N	-	-	-	-	-	28	-	-	-
s	1,5	2,0	2,0	2,5	3,0	3,0	3,5	4,0	4,5
t	5	10	10	15	15	20	25	20	20

1) Further sizes and Types available on request.
 2) Recommended tolerance connection H7/k6.

We reserve the right to make dimensional and constructional alterations.

Order number

_	/	9	4	0	.	_	2	2	.	_	/	_	/	_
▲						▲				▲		▲		▲
Sizes		Elast. element hardness 98 Sh A (red)				0	Aluminium design		A	Bore ø		Bore ø		
14		Elast. element hardness 92 Sh A (yellow)				1	up to size 38			d ₅ ^{H7}		(see Table)		
to		Elast. element hardness* 80 Sh A (blue)				5	Steel design		F					
65		Elast. element hardness 64 Sh D (green)				6	from size 42							

Example: 42 / 940.022.F / Ød₅ 30 / Ød₅ 30

*Only up to size 28

ROBA®-ES with clamping hubs Type 940._00._

Sizes 14 to 65

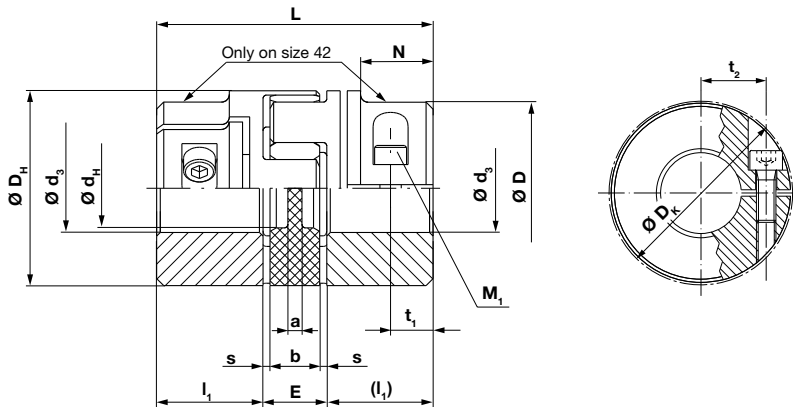

Fig. 2: Type 940._00._

ROBA®-ES couplings with clamping hubs are conceived for fast and safe installation or de-installation. They have no keyway. The tightening torque (T_A) on the clamping screws must be maintained in order to ensure reliable, frictionally-locking torque transmission.

Please observe the maximum permitted torques (Table 4, page 11).

Up to size 38, the hubs are made of aluminium. From size 42, they are made of steel.

The clamping hub can be designed with an additional keyway on request.

Technical Data and Bores			Size ¹⁾									
			14	19	24	28	38	42	48	55	65	
Minimum hub bore ²⁾	$d_{3\min}$	[mm]	6	10	15	19	20	28	35	40	45	
Maximum hub bore ²⁾	$d_{3\max}$	[mm]	15	20	28	35	45	45	55	70	80	
Maximum speed	n_{\max}	[rpm]	19000	14000	10600	8500	7100	6000	5600	5000	4600	
Mass moments of inertia	per hub and max. bore	J	[10 ⁻⁶ kgm ²]	2,8	20,4	50,8	200,3	400,6	2246	3786	9676	17872
Weight			[kg]	0,020	0,066	0,132	0,253	0,455	1,85	2,52	3,89	5,62
Tightening torques	Socket set screws	T_A	[Nm]	1,4	10	10	25	25	25	90	110	200

Dimensions	Size ¹⁾								
	14	19	24	28	38	42	48	55	65
a	2	4	4	5	5	5	5	9	8
b	10	12	14	15	18	20	21	22	26
D	-	-	-	-	-	75	-	-	-
D_H	30	40	55	65	80	95	105	120	135
D_K	32,2	47	56,4	72,6	83,3	78,8	108	122	139
d_H	10,5	18	27	30	38	46	51	60	68
E	13	16	18	20	24	26	28	30	35
L	35	66	78	90	114	126	140	160	185
l_1	11	25	30	35	45	50	56	65	75
M_1	M3	M6	M6	M8	M8	M8	M12	M12	M14
N	-	-	-	-	-	28	-	-	-
s	1,5	2,0	2,0	2,5	3,0	3,0	3,5	4,0	4,5
t_1	5,5	12	12	13,5	20	20	21	26	27,5
t_2	11	14	20	24	30	27,5	36	45	52

1) Further sizes and Types available on request.

2) For transmittable torques dependent on bore, see Table 4, page 11.

We reserve the right to make dimensional and constructional alterations.

Order number

—	/	9	4	0	.	—	0	0	.	—	/	—	/	—
▲						▲				▲		▲		▲
Sizes		Elast. element hardness 98 Sh A (red)				0	Aluminium design up to size 38		A	Bore $\varnothing d_3^{F7}$		Bore $\varnothing d_3^{F7}$		
14		Elast. element hardness 92 Sh A (yellow)				1	Steel design from size 42		F	(see Table)		In the slotted area, the bore tolerances can deviate		
to		Elast. element hardness* 80 Sh A (blue)				5								
65		Elast. element hardness 64 Sh D (green)				6								

Example: 42 / 940.000.F / $\varnothing d_3$ 30 / $\varnothing d_3$ 30

*Only up to size 28

ROBA®-with aluminium shrink disk hubs Type 940._11.A

Sizes 14 to 38

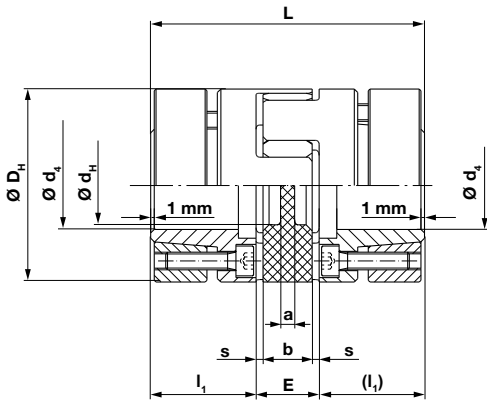

On this design, the hub body is made of aluminium and the ring of phosphated, annealed steel. The design is constructionally identical to the P-design (page 9). The symmetry, the absence of keyways and radial bores produces an optimum shaft run out. Therefore, much higher torques are possible compared to the other hub designs (please observe the Balancing Diagram, page 12).

The torque is transmitted via frictional locking onto the shaft. Therefore, please observe the maximum torques on this shaft-hub connection (Table 1, page 10).

Fig. 3: Type 940._11.A

Technical Data and Bores			Size					
			14	19	24	28	38	
Minimum hub bore ¹⁾	$d_{4 \text{ min}}$	[mm]	6	10	15	19	20	
Maximum hub bore ¹⁾	$d_{4 \text{ max}}$	[mm]	14	20	28	38	45	
Maximum speed	n_{max}	[rpm]	28000	21000	15500	13200	10500	
Mass moments of inertia	per hub and max. bore	J	[10 ⁻⁶ kgm ²]	7	31	135	313	960
Weight			[kg]	0,049	0,12	0,28	0,45	0,95
Tightening torques	Clamping screws	T_A	[Nm]	1,3	3,0	6,0	6,0	10,0

Dimensions	Size				
	14	19	24	28	38
a	2	4	4	5	5
b	10	12	14	15	18
D_H	30	40	55	65	80
d_H	10,5	18	27	30	38
E	13	16	18	20	24
L	50	66	78	90	114
l_1	18,5	25	30	35	45
M_2	4 x M3	6 x M4	4 x M5	8 x M5	8 x M6
s	1,5	2,0	2,0	2,5	3,0

1) For transmittable torques dependent on bore, see Table 1, page 10.

We reserve the right to make dimensional and constructional alterations.

Order number

—	/	9	4	0	.	—	1	1	.	A	/	—	/	—
▲						▲				▲		▲		▲
Sizes	Elast. element hardness 98 Sh A (red)						Aluminium design			A		Bore \varnothing		Bore \varnothing
14	Elast. element hardness 92 Sh A (yellow)											d_4^{H7}		d_4^{H7}
to	Elast. element hardness* 80 Sh A (blue)											(see Table)		(see Table)
38	Ealst. element hardness 64 Sh D (green)													

Example: 38 / 940.011.A / $\varnothing d_4$ 30 / $\varnothing d_4$ 30

*Only up to size 28

ROBA®-ES with steel shrink disk hubs Type 940._11._

Sizes 14-32 to 65

On this design, the hub body is made of steel (oiled) and the ring of phosphated, annealed steel. This design is available in a standard variant and a variant according to DIN 69002. The DIN variant has an elastomeric element with a central, standardised bore and standardised bore diameters in the hubs. The DIN variants are

conceived for use in short bore spindles and multi-spindle heads. Because of the steel hubs, this DIN design combines robustness with precision. This design should be selected in preference to others, in particular on applications with heavily tumescent or alternating loads.

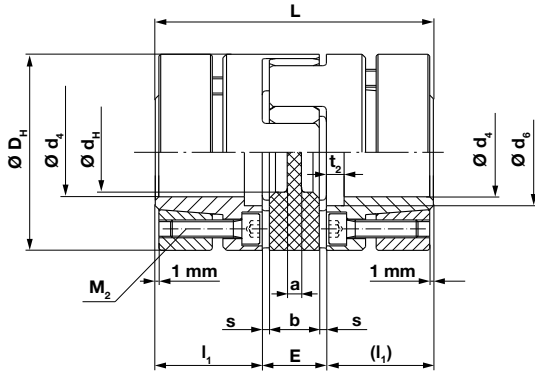

Fig. 4: Type 940._11.P – Sizes 14 to 38
Type 940._11.F – Sizes 42 to 65

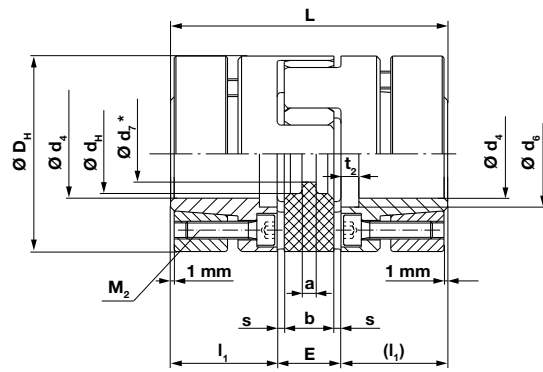

Fig. 5: Type 940.011.P
Sizes 14-32 to 28 acc. DIN 69002

Technical Data and Bores			Size										
			14-32	19-37,5	19	24-50	24	28	38	42	48	55	65
Minimum hub bore ¹⁾	$d_{4\min}$	[mm]	6	10	10	15	15	19	20	28	35	40	45
Maximum hub bore ¹⁾	$d_{4\max}$	[mm]	14	16	20	24	28	38	45	50	60	70	75
DIN-bore *	d_4	[mm]	14	16	19	24	25	35	-	-	-	-	-
Maximum speed	n_{\max}	[rpm]	28000	21000	21000	15500	15500	13200	10500	9000	8000	6300	5600
Mass moments of inertia	J	[10 ⁻⁶ kgm ²]	11	37	46	136	201	438	1320	3170	5200	9069	17209
Weight		[kg]	0,1	0,16	0,19	0,33	0,44	0,64	1,3	2,3	3,1	3,61	5,52
Tightening torques	T_A	[Nm]	1,3	3,0	3,0	6,0	6,0	6,0	10	25	30	52	90

Dimensions	Size											
	14-32	19-37,5	19	24-50	24	28	38	42	48	55	65	
a	2	4	4	4	4	5	5	5	5	9	8	
b	10	12	12	14	14	15	18	20	21	22	26	
D_H	32	37,5	40	50	55	65	80	95	105	120	135	
d_H	10,5	18	18	27	27	30	38	46	51	60	68	
d_6	17	19	22	29	30	40	46	55	60	72	77	
d_7^*	8,5	9,5	9,5	12,5	12,5	14,5	-	-	-	-	-	
E	13	16	16	18	18	20	24	26	28	30	35	
L	50	66	66	78	78	90	114	126	140	160	185	
l_1	18,5	25	25	30	30	35	45	50	56	65	75	
M_2	4 x M3	6 x M4	6 x M4	4 x M5	4 x M5	8 x M5	8 x M6	4 x M8	4 x M8	4 x M10	4 x M12	
s	1,5	2,0	2,0	2,0	2,0	2,5	3,0	3,0	3,5	4,0	4,5	
t_2	3	4	4	5	5	5	5	5	6	7	7	

1) For transmittable torques dependent on bore, see Tables 2 and 3, pages 10 and 11. We reserve the right to make dimensional and constructional alterations.
* Elastomeric elements with DIN bore only available with 98 Sh A (red), Type 940.011.P

Order number

___ / 9 4 0 . ___ 1 1 . ___ / ___ / ___ / ___											
▲		▲		▲		▲	▲	▲	▲		▲
Sizes	Elast. element hardness 98 Sh A (red)	0	Steel design up to size 38	P	Bore \varnothing d_4^{H6}	Bore \varnothing d_4^{H6}	Design				
14-32	Elast. element hardness 92 Sh A (yellow)	1					- DIN				
to	Elast. element hardness* 80 Sh A (blue)	5	Steel design from size 42	F	(see Table)	(see Table)	- No values for standard				
65	Elast. element hardness 64 Sh D (green)	6									

Example: 42 / 940.011.F / $\varnothing d_4$ 30 / $\varnothing d_4$ 30

*Only up to size 28

Transmittable torques for shrink disk hubs made of aluminium – dependent on bore - Type 940_11.A

	Bore	Size				
		14	19	24	28	38
Frictionally-locking transmittable torques Shrink disk hubs made of aluminium	Ø6	7	-	-	-	-
	Ø7	9	-	-	-	-
	Ø8	11	-	-	-	-
	Ø9	13	-	-	-	-
	Ø10	15	33	-	-	-
	Ø11	17	38	-	-	-
	Ø14	24	55	-	-	-
	Ø15	-	61	56	-	-
	Ø16	-	67	62	-	-
	Ø17	-	73	68	-	-
	Ø18	-	78	74	-	-
	Ø19	-	84	81	141	-
	Ø20	-	88	87	153	197
	Ø22	-	-	100	177	228
	Ø24	-	-	120	203	261
	Ø25	-	-	125	216	279
	Ø28	-	-	135	256	332
	Ø30	-	-	-	282	368
	Ø32	-	-	-	308	405
	Ø35	-	-	-	343	460
Ø38	-	-	-	373	513	
Ø40	-	-	-	-	547	
Ø42	-	-	-	-	577	
Ø45	-	-	-	-	617	

Table 1 The transmittable torques on the clamping connection take the max. tolerance backlash for shaft tolerance k6 / bore H7 into account. With larger tolerance backlash, the torque is reduced.

Transmittable torques for shrink disk hubs made of steel – dependent on bore - Type 940_11.P

	Bore	Size						
		14-32	19-37,5	19	24-50	24	28	38
Frictionally-locking transmittable torques Shrink disk hubs made of steel	Ø6	7	-	-	-	-	-	-
	Ø7	9	-	-	-	-	-	-
	Ø8	11	-	-	-	-	-	-
	Ø9	13	-	-	-	-	-	-
	Ø10	15	26	33	-	-	-	-
	Ø11	17	30	38	-	-	-	-
	Ø14	25	45	55	-	-	-	-
	Ø15	-	50	61	45	56	-	-
	Ø16	-	60	67	50	62	-	-
	Ø17	-	-	73	54	68	-	-
	Ø18	-	-	78	60	74	-	-
	Ø19	-	-	84	65	81	141	-
	Ø20	-	-	88	70	87	153	197
	Ø22	-	-	-	85	100	177	228
	Ø24	-	-	-	112	120	203	261
	Ø25	-	-	-	-	125	216	279
	Ø28	-	-	-	-	135	256	332
	Ø30	-	-	-	-	-	282	368
	Ø32	-	-	-	-	-	308	405
	Ø35	-	-	-	-	-	343	460
Ø38	-	-	-	-	-	373	513	
Ø40	-	-	-	-	-	-	547	
Ø42	-	-	-	-	-	-	577	
Ø45	-	-	-	-	-	-	617	

Table 2 The transmittable torques on the clamping connection take the max. tolerance backlash for shaft tolerance k6 / bore H6 into account. With larger tolerance backlash, the torque is reduced.

Transmittable torques for shrink disk hubs made of steel – dependent on bore – Type 940._11.F

		Bore	Size				
			42	48	55	65	
Frictionally-locking transmittable torques Shrink disk hubs made of steel	T_R	[Nm]	Ø28	300	-	-	-
			Ø30	350	-	-	-
			Ø32	400	-	-	-
			Ø35	500	450	-	-
			Ø38	600	500	-	-
			Ø40	680	600	723	-
			Ø42	730	720	814	-
			Ø45	790	850	946	1402
			Ø48	850	1000	1085	1596
			Ø50	880	1180	1187	1731
			Ø52	-	1270	1284	1873
			Ø55	-	1353	1436	2095
			Ø58	-	1428	1585	2308
			Ø60	-	1471	1682	2420
			Ø62	-	-	1795	2570
			Ø65	-	-	1943	2750
			Ø68	-	-	2100	2989
Ø70	-	-	2207	3157			
Ø72	-	-	-	3306			
Ø75	-	-	-	3550			

Table 3 The transmittable torques on the clamping connection take the max. tolerance backlash for shaft tolerance k6 / bore H7 into account. With larger tolerance backlash, the torque is reduced.

Transmittable torques for clamping hubs – dependent on bore – Type 940._00._

		Bore	Size										
			14	19	24	28	38	42	48	55	65		
Frictionally-locking transmittable torques Clamping hubs	T_R	[Nm]	Ø6	2,5	-	-	-	-	-	-	-	-	-
			Ø7	3,0	-	-	-	-	-	-	-	-	-
			Ø8	3,4	-	-	-	-	-	-	-	-	-
			Ø9	3,8	-	-	-	-	-	-	-	-	-
			Ø10	4,2	23	-	-	-	-	-	-	-	-
			Ø11	4,7	25	-	-	-	-	-	-	-	-
			Ø12	5,1	27	-	-	-	-	-	-	-	-
			Ø14	6,0	32	-	-	-	-	-	-	-	-
			Ø15	6,4	34	34	-	-	-	-	-	-	-
			Ø16	-	36	36	-	-	-	-	-	-	-
			Ø19	-	43	43	79	-	-	-	-	-	-
			Ø20	-	45	45	83	83	-	-	-	-	-
			Ø22	-	-	50	91	91	-	-	-	-	-
			Ø24	-	-	54	100	100	-	-	-	-	-
			Ø25	-	-	57	104	104	-	-	-	-	-
			Ø28	-	-	63	116	116	116	-	-	-	-
			Ø30	-	-	-	124	124	124	-	-	-	-
			Ø32	-	-	-	133	133	133	-	-	-	-
			Ø35	-	-	-	145	145	145	238	-	-	-
			Ø38	-	-	-	-	158	158	259	-	-	-
			Ø40	-	-	-	-	166	166	272	340	-	-
			Ø42	-	-	-	-	174	174	286	365	-	-
			Ø45	-	-	-	-	187	187	306	405	545	-
			Ø48	-	-	-	-	-	-	327	435	590	-
			Ø50	-	-	-	-	-	-	341	465	630	-
			Ø52	-	-	-	-	-	-	352	490	662	-
			Ø55	-	-	-	-	-	-	360	525	710	-
			Ø58	-	-	-	-	-	-	-	570	764	-
			Ø60	-	-	-	-	-	-	-	600	800	-
			Ø62	-	-	-	-	-	-	-	625	840	-
			Ø65	-	-	-	-	-	-	-	665	900	-
			Ø68	-	-	-	-	-	-	-	700	954	-
Ø70	-	-	-	-	-	-	-	740	990	-			
Ø72	-	-	-	-	-	-	-	-	1032	-			
Ø75	-	-	-	-	-	-	-	-	1095	-			
Ø78	-	-	-	-	-	-	-	-	1158	-			
Ø80	-	-	-	-	-	-	-	-	1200	-			

Table 4 The transmittable torques on the clamping connection take the max. tolerance backlash for shaft tolerance k6 / bore F7 into account. With larger tolerance backlash, the torque is reduced.

Technical Explanations

ROBA®-ES stands for flexible (E), backlash-free (S) shaft coupling. The device consists of two coupling hubs and a flexible, star-shaped intermediate ring (Fig. 6).

ROBA®-ES couplings are conceived specially for backlash-free operation at comparatively high speeds.

ROBA®-ES couplings are mainly used in measurement and regulatory technology as well as in control and procedure technology.

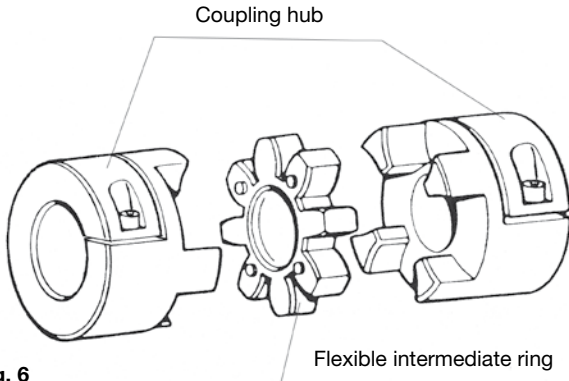

Fig. 6

Shaft Misalignments

The ROBA®-ES coupling is capable of compensating for radial, axial and angular shaft misalignments (Fig. 9), without losing their resistance to backlash. However, the permitted shaft misalignments shown on page 5 must not simultaneously reach their maximum value. If more than one kind of misalignment takes place simultaneously, they influence each other. This means that the permitted misalignment values are dependent on one another (see Fig. 8).

Therefore, the sum total of the actual misalignments in percent of the maximum value may not exceed 100 %.

The permitted misalignment values given on page 5 refer to coupling operation at nominal torque, an ambient temperature of +30 °C and an operating speed of 1500 rpm.

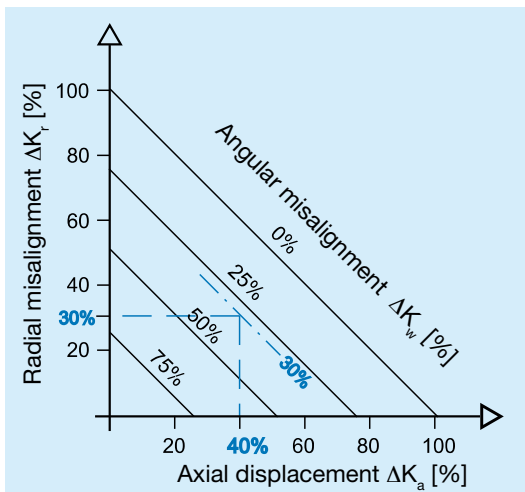

Fig. 8

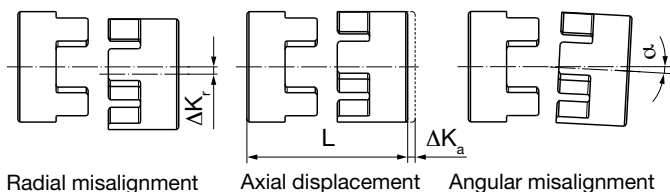

Fig. 9

State of Delivery

ROBA®-ES couplings are delivered manufacturer-assembled. The star-shaped intermediate ring must be pressed under light pre-tension (Fig. 7) into the specially formed jaws.

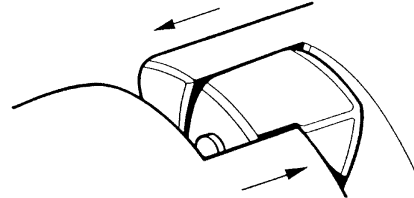

Fig. 7

The principle of backlash-free torque transmission is possible due to this pre-tension.

ROBA®-ES couplings are delivered in four torque variations; that is with four different flexible intermediate rings varying in shore hardness and colour (see Type key page 5).

Due to the small construction dimensions and therefore the low mass moments of inertia, the device allows itself to be installed even into small installation spaces.

Balancing

Key hubs and clamping hubs:

Key hubs and clamping hubs rotate at maximum speed with a circumferential speed of 30 m/s. They are not balanced for standard delivery.

Shrink disk hubs:

Shrink disk hubs can maintain balance quality $G = 6,3$ up to speed n_G (equals c. 30 m/s) without needing to be balanced. Above this speed, we recommend balancing. The hubs are balanced individually. Diagram 1 shows reference values. We recommend you use these values to balance the coupling components.

Smooth running of a machine or system is not only dependent on the balance quality of the coupling, but also on many parameters such as rigidity or distance to the adjacent bearing. Therefore there are no fixed rules in which conditions you have to balance.

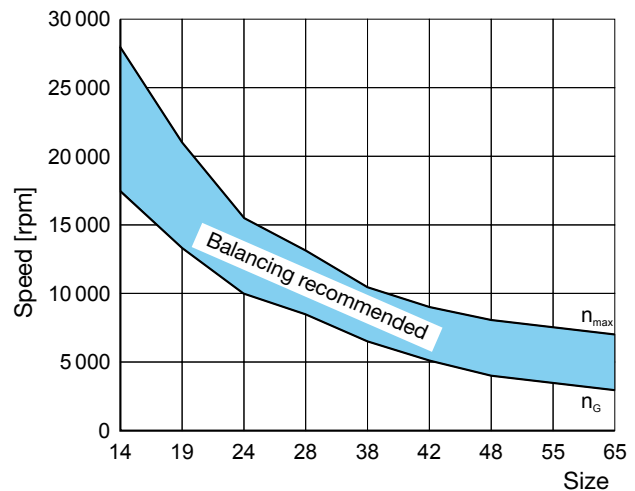

Diagram 1: Balancing the shrink disk hubs

Installation Guidelines – Installation

Due to its optimized construction, the ROBA®-ES coupling can be inserted axially onto the input or output shafts after installation of the hubs. Subsequent screwing-on and complicated special-construction housing is no longer necessary (see Installation Example page 10).

Please Observe!!!

The installation or installation dimensions must be kept to so that there is no facing-side pressure on the elastomeric element after clutch installation has been completed, meaning that the elastomeric element must not be distorted axially.

By keeping to the installation dimensions (in particular dimension “E”, see Dimension Figs. and Dimension Tables, pages 6 – 9), the elastomeric element’s axial flexibility remains guaranteed.

On elastomeric elements with differing numbers of nubs, the side with the larger number of nubs must be installed first (for easier installation).

Due to the pre-tension on the flexible elastomeric element, an axial installation force is required when joining the coupling hubs.

The axial installation force required can be reduced by lightly greasing the elastomeric element. **OBSERVE:** Only use grease based on mineral oil without additives. Vaseline is also suitable.

Installation of the shrink disk hubs (ROBA®-ES Type 940._11._)

The conical surfaces of the shrink disk hubs are greased manufacturer-side with a special grease (should the device be cleaned, the device must be re-greased with special grease).

- Push the shrink disk hubs using a suitable device into both shaft ends, align them and tighten the clamping screws lightly up to their limits.
- Tighten the clamping screws evenly stepwise and cross-wise to the specified tightening torque (see pages 8 and 9) using a torque wrench.
- **For de-installation**, loosen all clamping screws by several thread turns.
- The clamping screws located next to the tapped extracting holes must be screwed out, and then screwed into the tapped extracting holes up to their limits.
- Tighten the clamping screws evenly and crosswise. This forces the shrink disk away from the conical shrink disk hub.

Safety Regulations

The coupling rotates during operation. It must be secured customer-side against inadvertent contact. Installation and maintenance must be carried out by personnel who have been trained accordingly.

Installation Examples

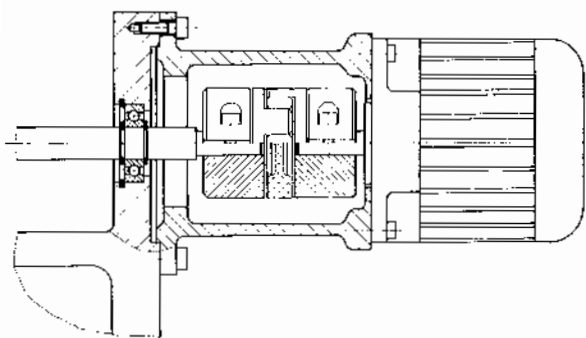

Fig. 10: ROBA®-ES with clamping hubs

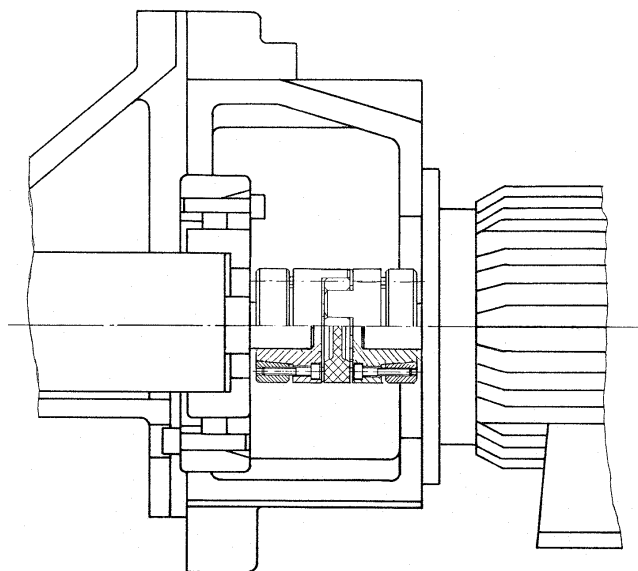

Fig. 12: ROBA®-ES with shrink disks

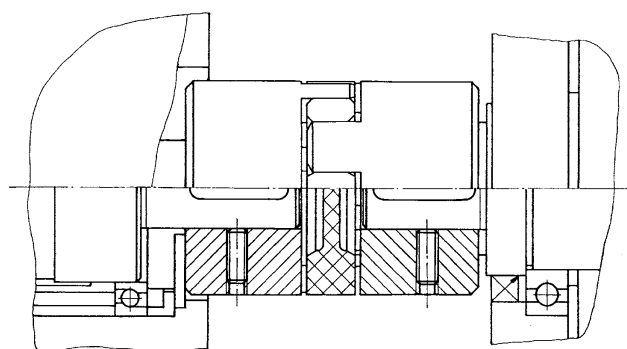

Fig. 11: ROBA®-ES with keyways

ROBA®-ES Coupling Dimensioning

1. Approximate calculation of the coupling torque:

1.1. T_N from the nominal capacity

$$T_N = \frac{9550 \times P_{AN/LN}}{n}$$

1.2. Dynamic torques T_S and T_W (5.1 and 5.2):

Input-side excitation:

Impact torque: $T_S = T_{AS} \times \frac{J_L}{J_A + J_L} \times S_A$

Alternating torque: $T_W = T_{AW} \times \frac{J_L}{J_A + J_L} \times V_R$

Load-side excitation:

Impact torque: $T_S = T_{LS} \times \frac{J_A}{J_A + J_L} \times S_L$

Alternating torque: $T_W = T_{LW} \times \frac{J_A}{J_A + J_L} \times V_R$

2. Comparison of torques occurring in the coupling with the permitted torques

The coupling must be dimensioned so that the loads occurring do not exceed the permitted values in any operating condition.

2.1. Load due to nominal torque

$$T_{KN} \geq T_N \times S_\delta$$

2.2. Load due to torque impacts (5.3)

$$T_{K \max} \geq T_S \times S_Z \times S_\delta + T_N \times S_\delta$$

2.3. Load due to resonance passing through (5.4)

$$T_{K \max} \geq T_S \times S_Z \times S_\delta \times V_R + T_N \times S_\delta$$

2.4. Load due to constantly alternating torque – cycle operation (5.5 and 5.6)

Permitted alternating torque on coupling:

$$T_{KW} = 0,25 \times T_{KN} \text{ (for aluminium hubs)}$$

$$T_{KW} = 0,35 \times T_{KN} \text{ (for steel hubs)}$$

$$T_{KW} \geq T_W \times S_\delta \times S_f$$

3. Inspection of permitted misalignments

$$\Delta K_a \geq \Delta W_a \times S_\delta$$

$$\Delta K_r \geq \Delta W_r \times S_\delta \times S_n$$

$$\Delta K_w \geq \Delta W_w \times S_\delta \times S_n$$

If more than one misalignment type occurs at the same time, please observe Fig. 8 (page 12).

4. Frictional locking inspection on hub connection

$T_R > T_{\max}$: T_{\max} is the maximum torque occurring in the coupling.

Values for T_R can be found on pages 10 and 11.

5. Explanations

5.1. The torque definition on the coupling is applicable if the shaft coupling in the system is the torsionally softest element, and therefore the system can be considered as a double-mass oscillator. If this is not the case, the calculation of the torque on the coupling requires a more detailed calculation procedure.

5.2. The impact factors S_A / S_L describe the impact progression. A rectangular progression of the impact torque is the heaviest impact ($S_A/S_L=2,0$). A flat sinus progression of the impact torque is a light impact ($S_A/S_L=1,2$).

5.3. T_S , the peak torque in the coupling, is the maximum torque on the coupling during the impact minus the system torque having an effect on the coupling during normal operation.

$$T_S = T_{\max. \text{ impact}} - T_N$$

5.4. If a drive is operated supercritically, meaning that the operating speed n lies above the resonance speed n_R , then resonance passing through causes particular loads.

If the resonance passes through quickly below the operating speed, only a few resonance peaks occur. The alternating torque in resonance can therefore be compared to the maximum torque on the coupling (see also 5.6)

5.5. S_f takes the frequency dependency of lifetime into account. The frequency dependency is first taken into account above 5 Hz.

5.6. On appreciable vibration excitation, the resonance must be moved out of the operating range by selecting a suitable coupling spring rigidity.

Service factors for Coupling Dimensioning

V_R = Resonance factor

n_R = Resonance speed

Blue: elast. element 80 Sh A $n_R = \frac{30}{\pi} \sqrt{C_{T \text{ dyn.}} \frac{J_A + J_L}{J_A \times J_L}}$ [rpm]
 Yellow: elast. element 92 Sh A
 Red: elast. element 98 Sh A
 Green: elast. element 64 Sh D

f_R = Resonance frequency

$f_R = \frac{1}{2\pi} \sqrt{C_{T \text{ dyn.}} \frac{J_A + J_L}{J_A \times J_L}}$ [Hz]

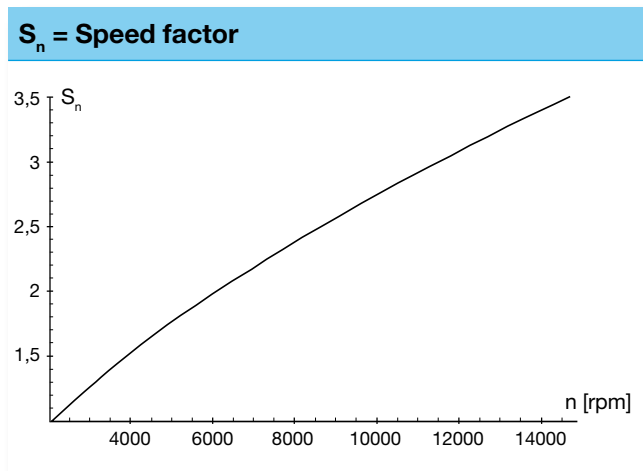

S_z = Start-up factor/impact frequency

S/h	0-100	101-200	201-400	401-800	801-1600
S_z	1	1,2	1,4	1,6	1,8

S_δ = Safety factor for temperature

T [°C]	- 30 °C / + 30 °C	+ 60 °C	+ 90 °C
S_δ	1	1,5	2

S_f = Frequency factor

f in H _z	≤ 5	> 5
S_f	1	$\sqrt{\frac{f}{5}}$

S_L or S_A = Impact factor

Impacts	S_A or S_L
Light impacts	1,2
Medium impacts	1,6
Heavy impacts	2,0

f shows the load alternation per second (Hz = s⁻¹)

Terms

$P_{AN/LN}$	[kW]	Input-side/load-side capacity	ΔK_r	[mm]	Permitted radial misalignment
T_R	[Nm]	Transmittable torque (frictional locking, Tables pages 10,11)	ΔK_w	[°]	Permitted angular misalignment
$T_{AS/AW}$	[Nm]	Excitational torque input-side	ΔW_a	[mm]	Axial shaft displacement
$T_{LS/LW}$	[Nm]	Excitational torque load-side	ΔW_r	[mm]	Radial shaft misalignment
T_N	[Nm]	System torque	ΔW_w	[°]	Angular shaft misalignment
T_W	[Nm]	System alternating torque	c_T	[Nm/rad]	Spring rigidity
T_S	[Nm]	Peak torque	n	[rpm]	Nominal speed
T_{max}	[Nm]	Maximum torque in the coupling	n_R	[rpm]	Resonance speed
T_{KN}	[Nm]	Permitted nominal torque	$S_{A/L}$	[-]	Impact factor input-side/load-side
T_{Kmax}	[Nm]	Permitted maximum torque	S_z	[-]	Start-up factor/impact frequency
T_{KW}	[Nm]	Permitted permanent alternating torque	S_δ	[-]	Temperature factor
J_A	[kgm ²]	Mass moment of inertia, input-side	S_f	[-]	Frequency factor
J_L	[kgm ²]	Mass moment of inertia, load-side	V_R	[-]	Resonance factor
ΔK_a	[mm]	Permitted axial displacement	f	[1/s]=[Hz]	Load factor
			f_R	[Hz]	Resonance frequency



Headquarters

Chr. Mayr GmbH + Co. KG
Eichenstrasse 1, D-87665 Mauerstetten
Tel.: 0 83 41/8 04-241, Fax: 0 83 41/80 44 22
www.mayr.de, eMail: info@mayr.de



mayr®

Service Germany

Baden-Württemberg

Roland Hanselmann
 Jochen Maurer
 Mittlere Holdergasse 5
 71672 Marbach
 Tel.: 0 71 44/1 80 34+35
 Fax: 0 71 44/1 53 20

Bavaria

Manfred Schwarz
 Eichenstrasse 1
 87665 Mauerstetten
 Tel.: 0 83 41/80 41 04
 Fax: 0 83 41/80 44 23

Chemnitz

Martin Schlabing
 Bornauer Strasse 205
 09114 Chemnitz
 Tel.: 03 71/4 74 18 96
 Fax: 03 71/4 74 18 95

Franken

Jochen Held
 Unterer Markt 9
 91217 Hersbruck
 Tel.: 0 91 51/81 48 64
 Fax: 0 91 51/81 62 45

Hagen

Detlef Bracht
 Im Langenstück 6
 58093 Hagen
 Tel.: 0 23 31/78 03 0
 Fax: 0 23 31/78 03 25

Kamen

Thomas Kant
 Lünener Strasse 211
 59174 Kamen
 Tel.: 0 23 07/23 63 85
 Fax: 0 23 07/24 26 74

North

Bernd Massmann
 Schiefer Brink 8
 32699 Extertal
 Tel.: 0 57 54/9 20 77
 Fax: 0 57 54/9 20 78

Rhine-Main

Wolfgang Rattay
 Jägerstrasse 4
 64739 Höchst
 Tel.: 0 61 63/48 88
 Fax: 0 61 63/46 47

Branch office

China

Mayr Zhangjiagang
 Power Transmission Co., Ltd.
 Changxing Road No. 16,
 215600 Zhangjiagang
 Tel.: 05 12/58 91-75 62
 Fax: 05 12/58 91-75 66
 info@mayr.cn

Great Britain

Mayr Transmissions Ltd.
 Valley Road, Business Park
 Keighley, BD21 4LZ
 West Yorkshire
 Tel.: 0 15 35/66 39 00
 Fax: 0 15 35/66 32 61
 sales@mayr.co.uk

France

Mayr France S.A.
 Z.A.L. du Minopole
 BP 16
 62160 Bully-Les-Mines
 Tel.: 03.21.72.91.91
 Fax: 03.21.29.71.77
 contact@mayr.fr

Italy

Mayr Italia S.r.l.
 Viale Veneto, 3
 35020 Saonara (PD)
 Tel.: 0 49/8 79 10 20
 Fax: 0 49/8 79 10 22
 info@mayr-italia.it

Singapore

Mayr Transmission (S) PTE Ltd.
 No. 8 Boon Lay Way Unit 03-06,
 TradeHub 21
 Singapore 609964
 Tel.: 00 65/65 60 12 30
 Fax: 00 65/65 60 10 00
 info@mayr.com.sg

Switzerland

Mayr Kupplungen AG
 Tobelackerstrasse 11
 8212 Neuhausen am Rheinfall
 Tel.: 0 52/6 74 08 70
 Fax: 0 52/6 74 08 75
 info@mayr.ch

USA

Mayr Corporation
 4 North Street
 Waldwick
 NJ 07463
 Tel.: 2 01/4 45-72 10
 Fax: 2 01/4 45-80 19
 info@mayrcorp.com

Representatives

Australia

Transmission Australia Pty. Ltd.
 22 Corporate Ave,
 3178 Rowville, Victoria
 Australien
 Tel.: 0 39/7 55 44 44
 Fax: 0 39/7 55 44 11
 info@transaus.com.au

China

Mayr Shanghai
 Representative Office
 Room 506, No. 1007,
 Zhongshan South No. 2 Road
 200030 Shanghai, VR China
 Tel.: 0 21/64 57 39 52
 Fax: 0 21/64 57 56 21
 sales@mayr.com.cn

India

National Engineering
 Company (NENCO)
 J-225, M.I.D.C.
 Bhosari Pune 411026
 Tel.: 02 02/7 47 45 29
 Fax: 02 02/7 47 02 29
 nenco@vsnl.com

Japan

Sumitomo HI-PTC
 Sales Co., Ltd.
 Kanda Kihara BLDG. 3-5-8
 Kandakaji-Cho, Chiyoda-Ku
 Tokyo J101-0045
 Tel.: 03/52 56 30 91
 Fax: 03/52 56 30 98
 Gotou.k@sumiju.co.jp

South Africa

Torque Transfer
 Private Bag 9
 Elandsfontein 1406
 Tel.: 0 11/3 45 80 00
 Fax: 0 11/9 74 05 24
 torque@bearings.co.za

South Korea

Mayr Korea Co. Ltd.
 60-11, Woongnam-Dong
 ROK Changwon
 Rep. of Korea
 Tel.: 0 55/2 62-40 24
 Fax: 0 55/2 62-40 25
 info@mayrkorea.com

Taiwan

German Tech Auto Co. Ltd.
 No. 58, Wu Chuan Road
 Wu-Ku Industrial Park
 Taipei Hsien, Taiwan
 Tel.: 02/22 99 02 37
 Fax: 02/22 99 02 39
 steve@zfgta.com.tw

Machine tools

Applications in China
 DTC. Co.Ltd.,
 Block 5th, No. 1699,
 East Zhulu Road,
 201700 Shanghai, China
 Tel.: 021/59883978
 Fax: 021/59883979
 dtcshanghai@online.sh.cn

More representatives:

Austria, Benelux States, Brazil, Canada, Czech Republic, Denmark, Finland, Greece, Hongkong, Hungary, Indonesia, Israel, Malaysia, New Zealand, Norway, Philippines, Poland, Romania, Russia, Slovakia, Slovenia, Spain, Sweden, Thailand, Turkey

You can find the complete address for the representative responsible for your area under www.mayr.de in the internet.

mayr®
 your reliable partner