

# HINDI 880 GATE OPERATOR

## Technical specifications

### ELECTRIC MOTOR

Power output.....	0.18 KW (0.25 HP)
Supply voltage/Frequency.....	230 V / 50 Hz
Absorbed power.....	250 W
Absorbed current.....	1.2 A
Motor rotation speed.....	1'350 r.p.m.
Capacitor.....	12.5 µF
Intermittent service.....	S3

### OIL-HYDRAULIC PISTON

Time of one stroke.....	24 s
Pump flow rate - P5.....	1.4 l/min.
Stroke.....	280 mm
Piston diameter.....	45 mm
Shaft diameter.....	20 mm
Thrust power.....	3'000 Nm
Average working pressure.....	1 MPa (10 bars)
Maximum working pressure.....	3 MPa (30 bars)
Type of hydraulic oil.....	FADINI A 15 by Agip
Working temperature.....	-20°C +80°C
Weight of HINDI 880 complete.....	11 Kg
Max. gate weight.....	150/180 Kg
Dimensions (L x W x H).....	1'085x92x110 mm
Protection standard.....	IP 553

### SERVICE

Duty cycle.....	24 sec. Opening - 30 sec. Dwell - 24 sec. Closing
Time of one complete cycle.....	78 s
No. of complete cycles: Open - Dwell - Close.....	46/hour
No. of cycles a year, 8 hours a day.....	134'000

**With non locking operators, an electric lock must be fitted to the gate that opens first.**

### NOTE WELL

All the oil-hydraulic operators, once installed, must be adjusted to the gate weight through the safety pressure valves. The valve "OPEN" must be set at a higher pressure than "CLOSE". The electric cable is supplied by the manufacturers with the operator in a suitable length and must be free to dangle. A remote control with unique code, an electronic programmer with several functions and safety accessories make the equipment fully automatic.

### WARNINGS

- Should the operator be removed for maintenance, servicing or repair, tighten the air bleeding screw to prevent oil coming out of the reservoir during transport.
- Do not throw away waste oil and packaging materials (cardboard, polystyrene, nylon) which must be disposed of properly through a specialised company.
- All the electrical equipment must be properly earthed.

## Accessories

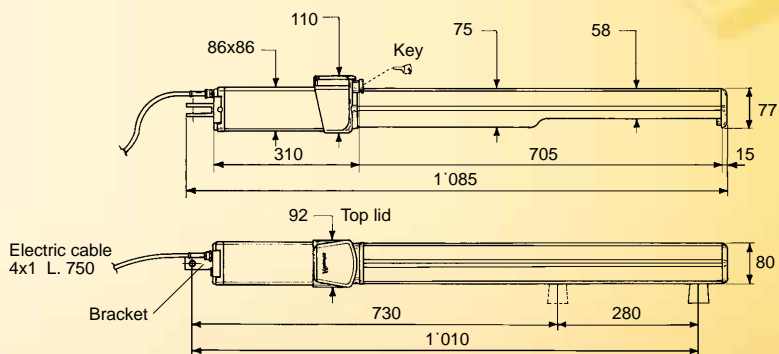
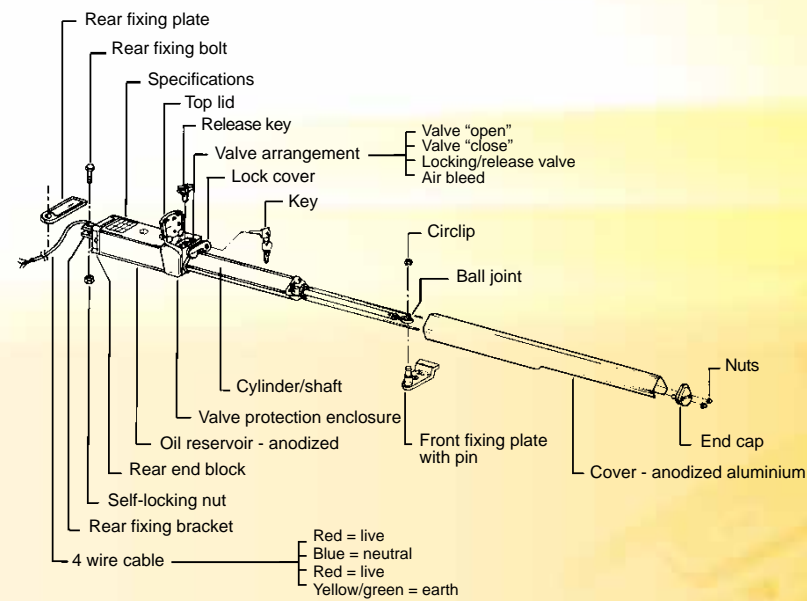

EUROPEAN MARK CERTIFYING CONFORMITY TO THE ESSENTIAL REQUIREMENTS OF THE STANDARDS 98/37 EC

- DECLARATION OF CONFORMITY
- GENERAL WARNINGS
- UNI 8612 STANDARDS
- CEI EN 60204-1 STANDARDS
- WARRANTY CERTIFICATE ON THE CUSTOMER'S REQUEST

The "CE" mark certifies that the operator conforms to the essential requirements of the European Directive art. 10 EEC 73/23, in relation to the manufacturer's declaration for the supplied items, in compliance with the body of the regulations ISO 9000-UNI EN 29000. Automation in conformity to UNI 8612 safety standards. The growth of MECCANICA FADINI has always been based on the development of guaranteed products thanks to our "TOTAL QUALITY CONTROL" system which ensures constant quality standards, updated knowledge of the European Standards and compliance with their requirements, in view of an ever increasing process of improvement.

# HINDI 880

Oil-hydraulic gate operator two-way locking in open and close directions



DISTRIBUTED BY  
**TRANSMISSION AUSTRALIA**  
☎ 1300 139 102  
www.transaus.com.au

The manufacturers reserve the right to change the products without any previous notice

**meccanica FADINI** s.n.c.  
AUTOMATIC GATE MANUFACTURERS



**FADINI**  
the gate opener

## Oil-hydraulic gate operator two-way locking in open and close directions

Oil-hydraulic gate operator **HINDI 880** is an electro-hydraulic unit fully self contained in that it encloses in itself all the parts for the generation and transmission of the motion to the gate by means of: electric motor, pump and oil distributing valve assembly that allows the shaft to move in and out and therefore to open and close the gate. It is weather-proof and designed to be easily installed to any gates by means of a bolt and fixing plates, one to the gate and one to the gate post, pillar or brick pier. Its technical features are the result of accurately designed and machined electric and mechanical parts, a guarantee of optimum performance and long lasting reliability. The electric motor has a class H winding and can well withstand the high increase in temperature during operations. It is coupled to the hydraulic pump/valve block by a special joint with two bearings so that the pump output revolutions are maintained constant. The pump is a lobe type, very smooth running. It is made of special steel material and is accurately tested to achieve a long lasting unit. The valve assembly is in the mid section of the operator, protected inside a suitable enclosure and well integrated in the shape and design of the whole mechanism.

Of new engineering conception, the assembly incorporates all the valves that control the required operations; the safety pressure valves for open and close, manual release, air bleed. With a key, that is supplied with the operator, it is possible to open the top lid and adjust the valves, which are properly identified with yellow stickers. Two-way hydraulic locking: it is a device incorporated in the hydraulic circuit in the valve assembly and it can 'lock', ie. hold the operator shaft (and consequently

the gate) in any desired position in either direction Open or Close. The locking device becomes operational when the electric motor stops; in events like power failure, manual operations are only possible by releasing this device first. The release valve is also located in the mid section under the cover lid and is to be turned anti-clockwise with a special spanner supplied with the equipment. Turn this valve clockwise to bring the operator back to its working condition. Bleeding the air out of the oil reservoir is essential to the performance of the unit. To this purpose, turn the air bleed screw by 1 to 2 turns by using a screwdriver. Re-tighten this screw to prevent oil coming out should the operator ever be removed for service or transport. HINDI 880, thanks to its improved technical features, is smoother and even more reliable than the previous range of swinging gate operators, even in very severe environment conditions (-20°C +80°C). It is built with state-of-the-art technology, by using top quality materials and parts in full conformity with the European safety standards to achieve a long lasting, reliable unit. The cover, which is made of extruded, anodized aluminium, is the result of an accurate study aiming to a shape which is ideal in matching any gate pattern and providing functional mounting. The piston shaft is made of steel and is chromium treated to meet weather-proof requirements.

The front end is fitted with a shock mount ball joint, adjustable, to ensure flexibility and suitable clearance at joining parts during the motion. The rear end block of the operator provides a sealing base to the oil reservoir and a suitable support to the fixing bracket, which is designed to bear all the mechanical stress of the open/close operations. The electric cable is an ideal combination of oil-resisting, weather-proof features and flexibility to allow free movements.

HINDI 880 is the final result of research, study and more than 10 years' experience in the field of electro-hydraulic gate automation. Entirely designed and produced in the factories of Meccanica Fadini, tested in the most harsh conditions, it consolidates the reputation and prestige of the manufacturers.



- (A) End block with fixing bracket
- (B) End cap with logo
- (C) Ball joint. Details
- (D) Example of applications of the operator and some accessories
- (E) Example of applications of the operator and some accessories



(A)



(B)



(C)

Manual release key and special key for locking top lid covering safety pressure valves of two-way locking



(D)



(E)