

Ideal force limiter for linear motion

*In cam controlled
feed drives*

*As torque reaction arm for
shaft mounted gear boxes*

*As force limitation in
crank mechanisms*



EAS[®] -axial

Overload protection for linearly moved masses

- *Reliable force limitation*
- *High axial stiffness*
- *Automatic engagement*
- *Electrical drive disconnection by an integral sensor*

www.mayr.de

K.403.C.V04.GB

mayr[®]
power
transmission

EAS[®]-axial – Bi-directional overload protection

- * Limits tensile and compressive forces.
- * High grade materials, hardened functional elements, and superior manufacturing precision guarantee the excellent repetitive accuracy of the set force and increase the service life.
- * Backlash-free force transmission with high axial stiffness.
- * Immediate force interruption in the event of an overload.
- * Infinite adjustment of the disengaging force.
- * Free stroke in tensile and compressive directions can be specified.
- * EAS[®]-axial with integral limit switch provides a signal in case of an overload which can be used to shut down the drive.
- * By using an EAS[®]-axial and a cycle monitor, cyclic frequencies can be monitored and controlled.
- * **Force limitation for linear motion systems, e. g. crank mechanisms.**
- * **As torque support, e.g. shaft-mounted gearboxes.**
- * **In cam controlled feed drives.**

Mounting examples

In the case of a crank mechanism, various forces act on the connecting rod. Extremely high forces may arise at the top or bottom dead center of the crank, in spite of torque limitation, and, therefore, cause damage without a torque limiting clutch reacting.

By using an EAS[®]-axial it is guaranteed that the axial force acting on the connecting rod – independent of the position of the crank – does not exceed a certain adjusted value.

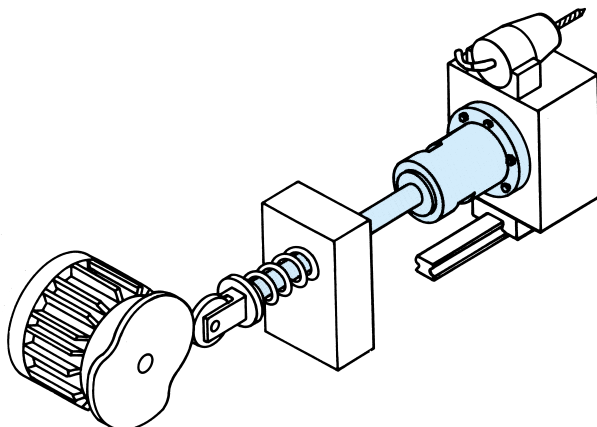
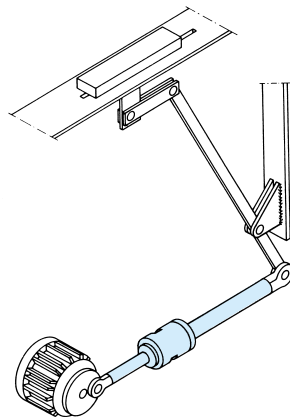

EAS[®]-axial in a cam controlled feed drive, for example a transfer line.
In the event of an overload, the EAS[®]-axial disengages and limits the force to the adjusted value.

The connecting rod telescopes into the EAS[®]-axial. During reversal the spring pulls the connecting rod back. The EAS[®]-axial engages and is ready for operation again automatically.

EAS[®]-axial

EAS[®]-axial with integral *mayr*[®]-limit switch

- * Provides signal for monitoring and control.
- * In the event of an overload, the drive is shut down or other control functions are initiated.
- * Contactless monitoring system.
- * Flexible installation of the EAS[®]-axial.
- * Direct signal evaluation.
- * Security against cable breakage is guaranteed by using PNP-opener (fail safe).
- * Short functional design, compact overall dimensions.

EAS[®]-axial with cycle monitoring system

- * Provides signal for monitoring and control.
- * In the event of an overload, the signal can be used to shut down the drive.

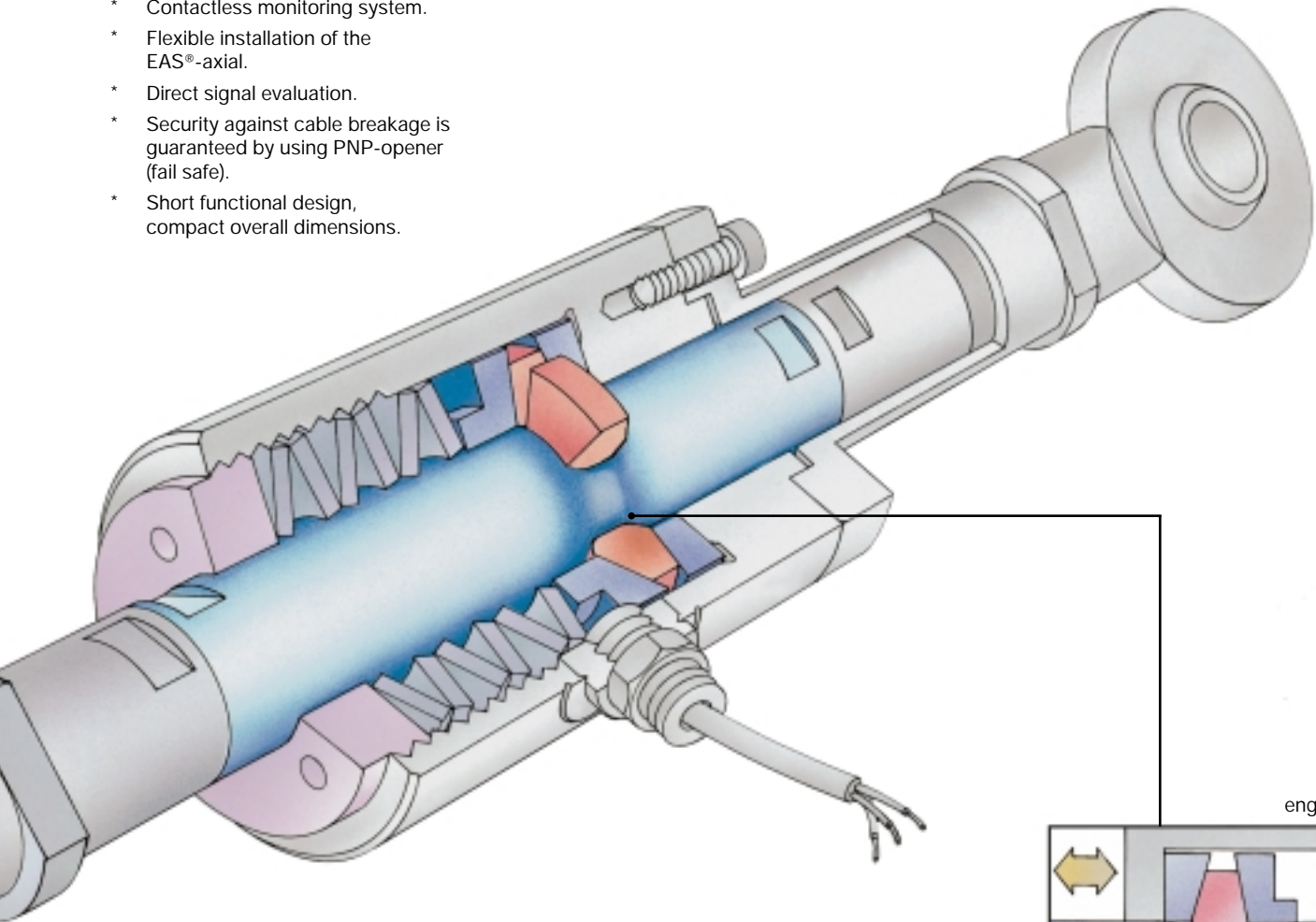

Operating principle of the EAS[®]-axial

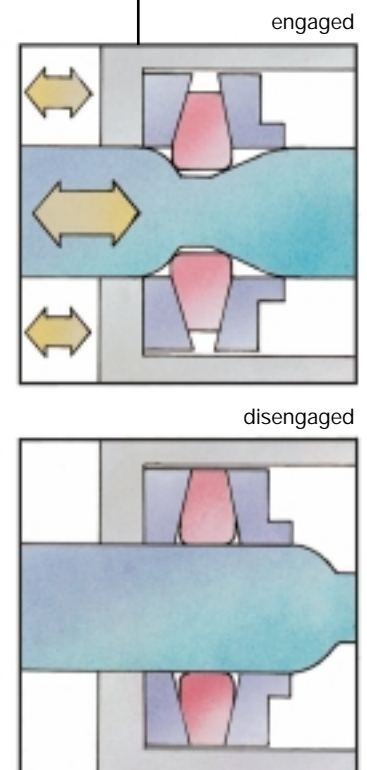

- * When the pre-set tensile or compressive force is exceeded, the EAS-axial[®] disengages in the respective direction.
- * The disengaging force is infinitely adjustable via an adjusting ring and *mayr*[®]-cup springs.
- * In the event of an overload, the bolt makes an axial stroke and moves the switching segments radially outward.
- * The force transmission is then interrupted.
- * Re-engagement manually or automatically.

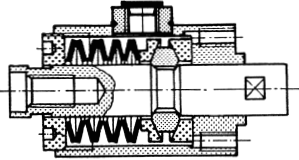
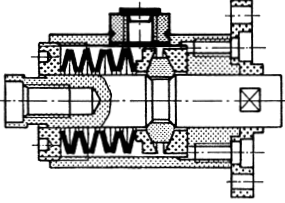
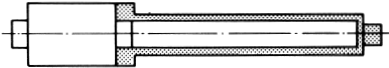
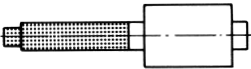
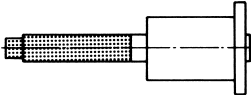
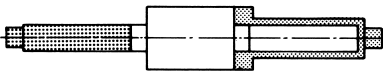

Summary of types

	Type	Disengaging force (N)	Application
<p>Basic element</p> 	300._._0	75 – 300 000	<p>Overload protection for linearly moved masses. High axial stiffness. Backlash-free design. Rapid force drop. Overload can be signalled by means of a contactless limit switch.</p> <p>page 6</p>
<p>Exterior flange design</p> 	320._._0	75 – 300 000	<p>Force transmitted via bolt and exterior flange. Free strokes in tensile and / or compressive directions based on customer supplied attachment parts. Use for example in feed carriages.</p> <p>page 7</p>
<p>Basic element with sleeve</p> 	310._._0	75 – 300 000	<p>Force transmitted via bolt and threaded end of sleeve. Free strokes in compressive direction can be varied by customer supplied attachment parts up to a maximum limited by the sleeve length. Sleeve length acc. to customer's request in dependence on the reduced length.</p> <p>page 8</p>
<p>Basic element with connecting rod</p> 	301._._0	75 – 300 000	<p>Force transmitted via connecting rod and bolt pattern on housing. Connecting rod length is as required to accommodate the free stroke in a compressive direction based on customer's application.</p> <p>page 9</p>
<p>Exterior flange design with connecting rod</p> 	321._._0	75 – 300 000	<p>Force transmitted via connecting rod and exterior flange. Connecting rod length is as required to accommodate the free stroke in compressive direction based on customer's application.</p> <p>page 10</p>
<p>Basic element with sleeve and connecting rod</p> 	311._._0	75 – 300 000	<p>Force transmitted via connecting rod and threaded end of sleeve. Length of the connecting rod and sleeve are as required to accommodate free stroke in compressive direction based on customer's application.</p> <p>page 11</p>

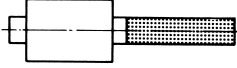
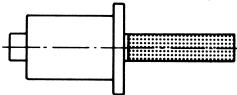
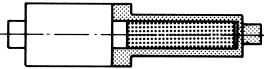
Summary of types

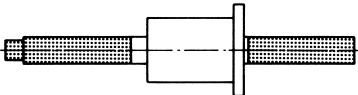
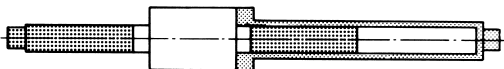
	Type	Disengaging force (N)	Application
<p>Basic element with guide rod</p> 	302.__0	75 – 300 000	<p>Force transmitted via bolt and housing. Guide rod length is as required to accommodate stroke in a tensile direction based on customer's application.</p> <p>page 12</p>
<p>Exterior flange design with guide rod</p> 	322.__0	75 – 300 000	<p>Force transmitted via bolt and exterior flange. Guide rod length is as required to accommodate stroke in a tensile direction based on customer's application.</p> <p>page 13</p>
<p>Basic element with guide rod and sleeve</p> 	312.__0	75 – 300 000	<p>Force transmitted via bolt and threaded end of sleeve. Length of guide rod and sleeve are as required to accommodate the free stroke in a tensile direction based on customer's application.</p> <p>page 14</p>
<p>Basic element with connecting rod and guide rod</p> 	303.__0	75 – 300 000	<p>Force transmitted via connecting rod and bolt pattern on housing. Length of connecting rod and guide rod are as required to accommodate free strokes in tensile and compressive directions based on customer's application.</p> <p>page 15</p>
<p>Exterior flange design with connecting rod and guide rod</p> 	323.__0	75 – 300 000	<p>Force transmitted via connecting rod and exterior flange. Length of connecting rod and guide rod are as required to accommodate free strokes in tensile and compressive directions based on customer's application.</p> <p>page 16</p>
<p>Basic element with connecting rod, guide rod, and sleeve</p> 	313.__0	75 – 300 000	<p>Force transmitted via connecting rod and threaded end of sleeve. Length of connecting rod, guide rod, and sleeve are as required to accommodate free strokes in tensile and compressive directions based on customer's application.</p> <p>page 17</p>
<p>Lenght layout calculation</p>			<p>page 18</p>
<p>Technical explanations</p>			<p>page 19</p>

Basic element

Type 300._ _ 0

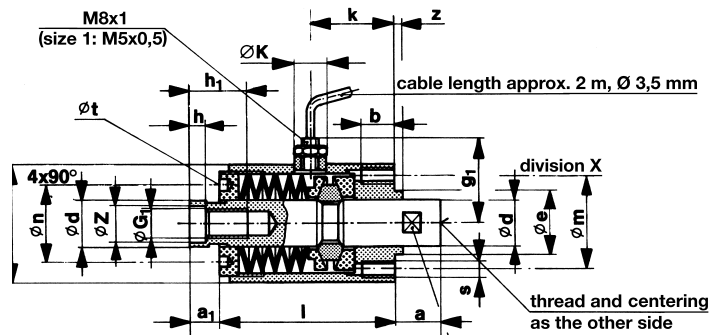

size 1 – 8 Type 300._ _ 0

Technical Data

Size	Disengaging forces ¹⁾ F _A [N]			Free stroke ²⁾ H _{1 max} , H _{2 max} [mm]	Weight [kg]
	Type 300.4_0	Type 300.5_0	Type 300.6_0		
1	75 – 200	200 – 500	300 – 800	max. 200	0,175
2	200 – 500	500 – 800	800 – 2000	max. 300	0,377
3	300 – 600	600 – 2000	2000 – 5000	max. 400	0,877
4	–	2000 – 6000	6000 – 12000	max. 500	2,45
5	3000 – 7500	6000 – 12000	12000 – 30000	max. 600	7,14
6	6000 – 12000	12000 – 30000	30000 – 70000	max. 700	12,9
7	12000 – 30000	30000 – 70000	70000 – 150000	max. 800	35,6
8	30000 – 70000	70000 – 150000	150000 – 300000	max. 1000	105,4

Table of dimensions

Size	a	a ₁	b	d _{h9}	e _{f7}	F	G ₁	g ₁	h	h ₁	K	k
1	8	6	7	10	14	30	M 6 x 0,75	43	5	12	15,5	18
2	12	10	10	14	18	37	M10 x 0,75	41	9	18	15,5	30
3	15	10	12	20	25	48	M12 x 1,0	47	10	22	15,5	33
4	20	15	15	30	35	68	M20 x 1,0	57	15	32	15,5	44
5	32,5	15	20	40	50	95	M24 x 1,5	67	20	42	–	59
6	35	15	22	50	60	120	M30 x 1,5	76	25	53	–	74
7	50	25	35	70	85	160	M48 x 2,0	89	35	73	–	114
8	65	30	50	100	120	240	M75 x 2,0	127	50	103	–	163

Size	L	l	m	n	s	t	x	Z ^{H7/h7}	z	SW
1	52	38	22	17	M 3	3	6 x 60°	7	2	9
2	75	53	28	22	M 5	4	6 x 60°	11	2	13
3	95	70	37	31	M 6	5	6 x 60°	13	3	17
4	130	95	52	48	M 8	6	6 x 60°	22	4	27
5	190	142,5	72	69	M 10	8	6 x 60°	28	6	36
6	230	180	90	90	M 12	8	6 x 60°	36	8	46
7	350	275	130	115	M 16	8	6 x 60°	52	10	65
8	460	365	180	170	M 24	10	6 x 60°	78	15	90

1) for lower or higher disengaging forces on request
re-engaging force = 20 – 25% of the set disengaging force

We reserve the right to make dimensional and design alterations.

2) H_{1 max}: free stroke in tensile direction; H_{2 max}: free stroke in compressive direction (larger free strokes on request)

Order example:

To be included when ordering, please state:	size	Type
Order number:		300._ _ 0

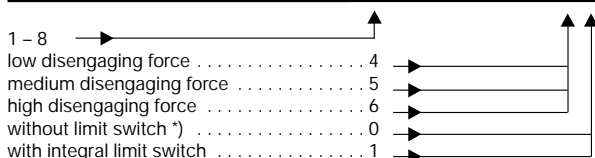

Example: order number 2 / 300.600

*) EAS[®]-axial without limit switch
• delivery with bushing (M8 or M5)

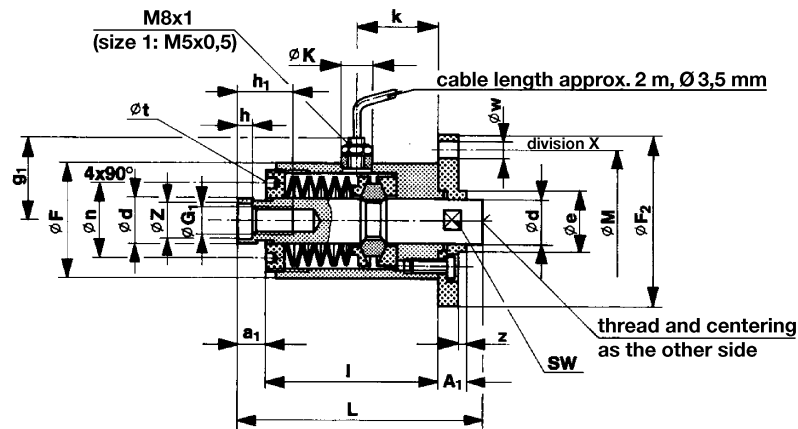

size 1 – 8 Type 320._ _ 0

Technical data

Size	Disengaging forces ¹⁾ F _A [N]			Free stroke ²⁾ H _{1 max} , H _{2 max} [mm]	Weight [kg]
	Type 320.4_0	Type 320.5_0	Type 320.6_0		
1	75 – 200	200 – 500	300 – 800	max. 200	0,225
2	200 – 500	500 – 800	800 – 2000	max. 300	0,487
3	300 – 600	600 – 2000	2000 – 5000	max. 400	1,087
4	–	2000 – 6000	6000 – 12000	max. 500	2,9
5	3000 – 7500	6000 – 12000	12000 – 30000	max. 600	8,31
6	6000 – 12000	12000 – 30000	30000 – 70000	max. 700	15,8
7	12000 – 30000	30000 – 70000	70000 – 150000	max. 800	42,0
8	30000 – 70000	70000 – 150000	150000 – 300000	max. 1000	124,9

Table of dimensions

Size	A ₁	a ₁	d _{h9}	e _{f7}	F	F ₂	G ₁	g ₁	h	h ₁	K	k
1	8	6	10	14	30	42	M 6 x 0,75	43	5	12	15,5	18
2	10	10	14	18	37	55	M10 x 0,75	41	9	18	15,5	30
3	12	10	20	25	48	70	M12 x 1,0	47	10	22	15,5	33
4	15	15	30	35	68	95	M20 x 1,0	57	15	32	15,5	44
5	21	15	40	50	95	128	M24 x 1,5	67	20	42	–	59
6	30	15	50	60	120	158	M30 x 1,5	76	25	53	–	74
7	40	25	70	85	160	210	M48 x 2,0	89	35	73	–	114
8	55	30	100	120	240	316	M75 x 2,0	127	50	103	–	163

Size	L	l	M	n	t	w	x	Z ^{H7} _{h7}	z	SW
1	52	38	36	17	3	3,4	6 x 60°	7	2	9
2	75	53	46	22	4	5,5	6 x 60°	11	2	13
3	95	70	60	31	5	6,6	6 x 60°	13	3	17
4	130	95	82	48	6	9	6 x 60°	22	4	27
5	190	142,5	112	69	8	11	6 x 60°	28	6	36
6	230	180	140	90	8	13,5	6 x 60°	36	8	46
7	350	275	186	115	8	17,5	6 x 60°	52	10	65
8	460	365	280	170	10	26	6 x 60°	78	15	90

1) for lower or higher disengaging forces on request
re-engaging force = 20 – 25% of the disengaging force

We reserve the right to make dimensional and design alterations.

2) H_{1 max}: free stroke in tensile direction; H_{2 max}: free stroke in compressive direction (larger free strokes on request)

Order example:

To be included when ordering, please state:	size	Type
Order number:		3 2 0 . _ _ 0

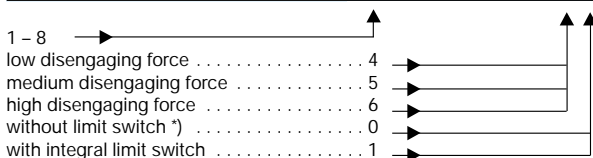

Example: order number 1 / 320.510

*) EAS®-axial without limit switch
• delivery with bushing (M8 or M5)

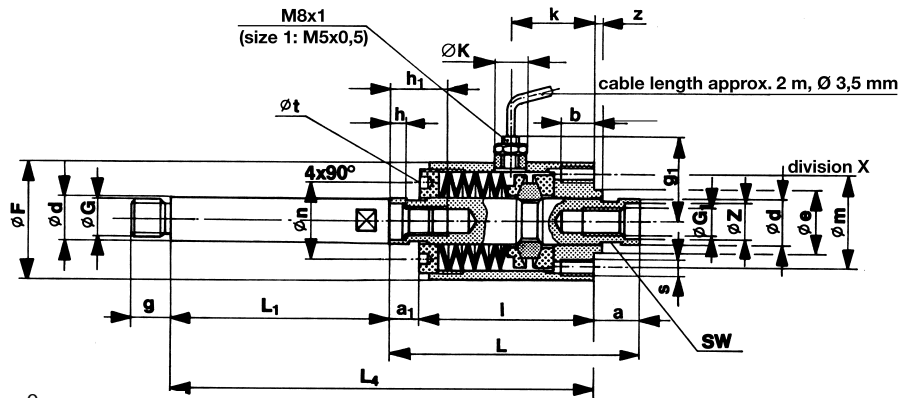

size 1 – 8 Type 301.__0

Technical data

Size	Disengaging forces ¹⁾ F _A [N]			Free stroke ²⁾ H _{2 max} [mm]
	Type 301.4_0	Type 301.5_0	Type 301.6_0	
1	75 – 200	200 – 500	300 – 800	max. 200
2	200 – 500	500 – 800	800 – 2000	max. 300
3	300 – 600	600 – 2000	2000 – 5000	max. 400
4	–	2000 – 6000	6000 – 12000	max. 500
5	3000 – 7500	6000 – 12000	12000 – 30000	max. 600
6	6000 – 12000	12000 – 30000	30000 – 70000	max. 700
7	12000 – 30000	30000 – 70000	70000 – 150000	max. 800
8	30000 – 70000	70000 – 150000	150000 – 300000	max. 1000

Table of dimensions

Size	a	a ₁	b	d _{h9}	e _{f7}	F	G	G ₁	g	g ₁	h	h ₁	K	k
1	8	6	7	10	14	30	M 8	M 6 x 0,75	10	43	5	12	15,5	18
2	12	10	10	14	18	37	M12	M10 x 0,75	15	41	9	18	15,5	30
3	15	10	12	20	25	48	M16	M12 x 1,0	20	47	10	22	15,5	33
4	20	15	15	30	35	68	M24 x 2	M20 x 1,0	30	57	15	32	15,5	44
5	32,5	15	20	40	50	95	M30 x 2	M24 x 1,5	35	67	20	42	–	59
6	35	15	22	50	60	120	M36 x 3	M30 x 1,5	42	76	25	53	–	74
7	50	25	35	70	85	160	M52 x 3	M48 x 2,0	50	89	35	73	–	114
8	65	30	50	100	120	240	M64 x 4	M75 x 2,0	60	127	50	103	–	163

Size	L	L ₁	L ₄	l	m	n	s	t	x	Z ^{H7/h7}	z	SW
1	52			38	22	17	M 3	3	6 x 60°	7	2	9
2	75	lengths depend on free stroke in		53	28	22	M 5	4	6 x 60°	11	2	13
3	95	tensile and		70	37	31	M 6	5	6 x 60°	13	3	17
4	130	compressive		95	52	48	M 8	6	6 x 60°	22	4	27
5	190	directions,		142,5	72	69	M 10	8	6 x 60°	28	6	36
6	230	calculation see		180	90	90	M 12	8	6 x 60°	36	8	46
7	350	page 18/19		275	130	115	M 16	8	6 x 60°	52	10	65
8	460			365	180	170	M 24	10	6 x 60°	78	15	90

1) for lower or higher disengaging forces on request re-engaging force = 20 – 25% of the disengaging force
 2) H_{2 max}: free stroke in tensile direction; (larger free strokes on request)

We reserve the right to make dimensional and design alterations.

Order example:

To be included when ordering, please state:	size	Type	length of the connecting rod
Order number:		301.__0	L ₁ =

- 1 – 8 →
- low disengaging force 4
- medium disengaging force 5
- high disengaging force 6
- without limit switch *) 0
- with integral limit switch 1

Calculation according to "design of length", see Technical data pages 18/19.

*) EAS®-axial without limit switch
 • delivery with bushing (M8 or M5)

Example: order number 1 / 301.400 / L₁ = 150

**Exterior flange design
with connecting rod**

Type 321._ _0

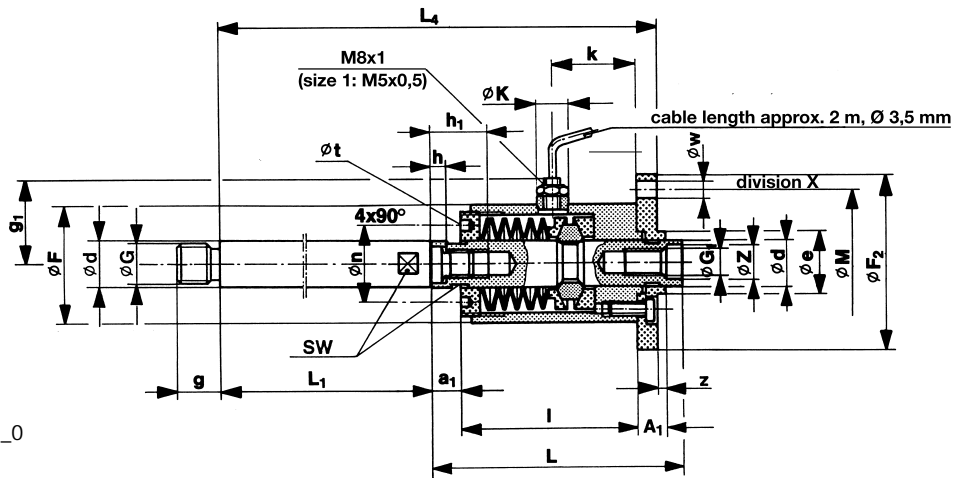

size 1 – 8 Type 321._ _0

Technical data

Size	Disengaging forces ¹⁾ F _A [N]			Free stroke ²⁾ H _{2 max} [mm]
	Type 321.4_0	Type 321.5_0	Type 321.6_0	
1	75 – 200	200 – 500	300 – 800	max. 200
2	200 – 500	500 – 800	800 – 2000	max. 300
3	300 – 600	600 – 2000	2000 – 5000	max. 400
4	–	2000 – 6000	6000 – 12000	max. 500
5	3000 – 7500	6000 – 12000	12000 – 30000	max. 600
6	6000 – 12000	12000 – 30000	30000 – 70000	max. 700
7	12000 – 30000	30000 – 70000	70000 – 150000	max. 800
8	30000 – 70000	70000 – 150000	150000 – 300000	max. 1000

Table of dimensions

Size	A ₁	a ₁	d _{h9}	e _{f7}	F	F ₂	G	G ₁	g	g ₁	h	h ₁	K	k
1	8	6	10	14	30	42	M 8	M 6 x 0,75	10	43	5	12	15,5	18
2	10	10	14	18	37	55	M12	M10 x 0,75	15	41	9	18	15,5	30
3	12	10	20	25	48	70	M16	M12 x 1,0	20	47	10	22	15,5	33
4	15	15	30	35	68	95	M24 x 2	M20 x 1,0	30	57	15	32	15,5	44
5	21	15	40	50	95	128	M30 x 2	M24 x 1,5	35	67	20	42	–	59
6	30	15	50	60	120	158	M36 x 3	M30 x 1,5	42	76	25	53	–	74
7	40	25	70	85	160	210	M52 x 3	M48 x 2,0	50	89	35	73	–	114
8	55	30	100	120	240	316	M64 x 4	M75 x 2,0	60	127	50	103	–	163

Size	L	L ₁	L ₄	l	M	n	t	w	x	Z ^{H7/h7}	z	SW
1	52			38	36	17	3	3,4	6 x 60°	7	2	9
2	75	lengths depend on free stroke		53	46	22	4	5,5	6 x 60°	11	2	13
3	95	in tensile and		70	60	31	5	6,6	6 x 60°	13	3	17
4	130	compressive		95	82	48	6	9	6 x 60°	22	4	27
5	190	directions,		142,5	112	69	8	11	6 x 60°	28	6	36
6	230	calculation see		180	140	90	8	13,5	6 x 60°	36	8	46
7	350	pages 18/19		275	186	115	8	17,5	6 x 60°	52	10	65
8	460			365	280	170	10	26	6 x 60°	78	15	90

1) for lower or higher disengaging forces on request
re-engaging force = 20 – 25% of the disengaging force
2) H_{2 max}: free stroke in compressive direction (larger free strokes on request)

We reserve the right to make dimensional and design alterations.

Order example:

To be included when ordering, please state:	size	Type	length of the connecting rod
Order number:		3 2 1 . _ _ 0	L ₁ =

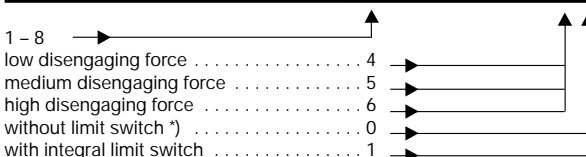

Calculation according to "design of length", see Technical data pages 18/19.

Example: order number 4 / 321.600 / L₁ = 320

^{*)} EAS[®]-axial without limit switch
• delivery with bushing (M8 or M5)

Basic element with sleeve and connecting rod

Type 311.__0

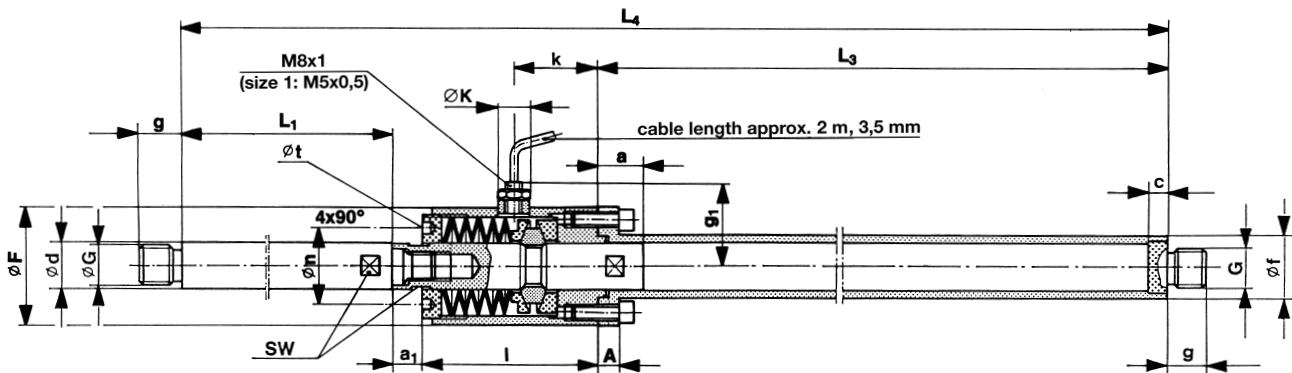

size 1 – 8 Type 311.__0

Technical data

Size	Disengage forces ¹⁾ F _A [N]			Free stroke ²⁾ H _{2 max} [mm]
	Type 311.4_0	Type 311.5_0	Type 311.6_0	
1	75 – 200	200 – 500	300 – 800	max. 200
2	200 – 500	500 – 800	800 – 2000	max. 300
3	300 – 600	600 – 2000	2000 – 5000	max. 400
4	–	2000 – 6000	6000 – 12000	max. 500
5	3000 – 7500	6000 – 12000	12000 – 30000	max. 600
6	6000 – 12000	12000 – 30000	30000 – 70000	max. 700
7	12000 – 30000	30000 – 70000	70000 – 150000	max. 800
8	30000 – 70000	70000 – 150000	150000 – 300000	max. 1000

Table of dimensions

Size	A	a	a ₁	c	d _{h9}	F	f	G	g
1	7	8	6	5	10	30	14	M 8	10
2	8	12	10	6	14	37	19	M12	15
3	10	15	10	8	20	48	26	M16	20
4	12	20	15	10	30	68	38	M24 x 2	30
5	15	32,5	15	12,5	40	95	55	M30 x 2	35
6	22	35	15	16	50	120	70	M36 x 3	42
7	32	50	25	20	70	160	95	M52 x 3	50
8	44	65	30	26	100	240	130	M64 x 4	60

Size	g ₁	K	k	L ₁	L ₃	L ₄	l	n	t	SW
1	43	15,5	18	lengths depend on free stroke in tensile and compressive directions, calculation see pages 18/19			38	17	3	9
2	41	15,5	30				53	22	4	13
3	47	15,5	33				70	31	5	17
4	57	15,5	44				95	48	6	27
5	67	–	59				142,5	69	8	36
6	76	–	74				180	90	8	46
7	89	–	114				275	115	8	65
8	127	–	163				365	170	10	90

1) for lower or higher disengaging forces on request
re-engaging force = 20 – 25% of the disengaging force
2) H_{2 max}: free stroke in compressive direction (larger free strokes on request)

We reserve the right to make dimensional and design alterations.

Order example:

To be included when ordering, please state:	size	Type	length of the connecting rod	length of the sleeve
Order number:		3 1 1 . _ _ 0	L ₁ =	L ₃ =

- 1 – 8 →
- low disengaging force 4
- medium disengaging force 5
- high disengaging force 6
- without limit switch *) 0
- with integral limit switch 1

Calculation according to "design of length", see Technical data pages 18/19.

Example: order number 3 / 311.510 / L₁ = 230 / L₃ = 320

*) EAS®-axial without limit switch
• delivery with bushing (M8 or M5)

Basic element with guide rod

Type 302._ _0

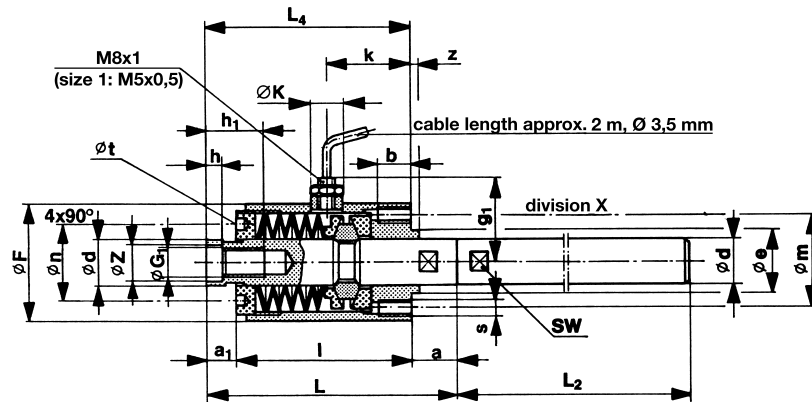

size 1 – 8 Type 302._ _0

Technical data

Size	Disengaging forces ¹⁾ F _A [N]			Free stroke ²⁾ H _{1 max} [mm]
	Type 302.4_0	Type 302.5_0	Type 302.6_0	
1	75 – 200	200 – 500	300 – 800	max. 200
2	200 – 500	500 – 800	800 – 2000	max. 300
3	300 – 600	600 – 2000	2000 – 5000	max. 400
4	–	2000 – 6000	6000 – 12000	max. 500
5	3000 – 7500	6000 – 12000	12000 – 30000	max. 600
6	6000 – 12000	12000 – 30000	30000 – 70000	max. 700
7	12000 – 30000	30000 – 70000	70000 – 150000	max. 800
8	30000 – 70000	70000 – 150000	150000 – 300000	max. 1000

Table of dimensions

Size	a	a ₁	b	d _{h9}	e _{f7}	F	G ₁	g ₁	h	h ₁	K	k	L
1	8	6	7	10	14	30	M 6 x 0,75	43	5	12	15,5	18	52
2	12	10	10	14	18	37	M10 x 0,75	41	9	18	15,5	30	75
3	15	10	12	20	25	48	M12 x 1,0	47	10	22	15,5	33	95
4	20	15	15	30	35	68	M20 x 1,0	57	15	32	15,5	44	130
5	32,5	15	20	40	50	95	M24 x 1,5	67	20	42	–	59	190
6	35	15	22	50	60	120	M30 x 1,5	76	25	53	–	74	230
7	50	25	35	70	85	160	M48 x 2,0	89	35	73	–	114	350
8	65	30	50	100	120	240	M75 x 2,0	127	50	103	–	163	460

Size	L ₂	L ₄	l	m	n	s	t	x	Z _{h7} ^{H7}	z	SW
1	lengths depend on free stroke in tensile and compressive directions, calculation see pages 18/19		38	22	17	M 3	3	6 x 60°	7	2	9
2			53	28	22	M 5	4	6 x 60°	11	2	13
3			70	37	31	M 6	5	6 x 60°	13	3	17
4			95	52	48	M 8	6	6 x 60°	22	4	27
5			142,5	72	69	M 10	8	6 x 60°	28	6	36
6			180	90	90	M 12	8	6 x 60°	36	8	46
7			275	130	115	M 16	8	6 x 60°	52	10	65
8			365	180	170	M 24	10	6 x 60°	78	15	90

1) for lower or higher disengaging forces on request re-engaging force = 20 – 25% of the disengaging force
2) H_{1 max}: free stroke in tensile direction (larger free strokes on request)

We reserve the right to make dimensional and design alterations.

Order example:

To be included when ordering, please state:	size	Type	length of the guide rod
Order number:		302._ _0	L ₂ =



Calculation according to "design of length", see Technical data pages 18/19.

*) EAS[®]-axial without limit switch
• delivery with bushing (M8 or M5)

Example: order number 1 / 302.500 / L₂ = 135

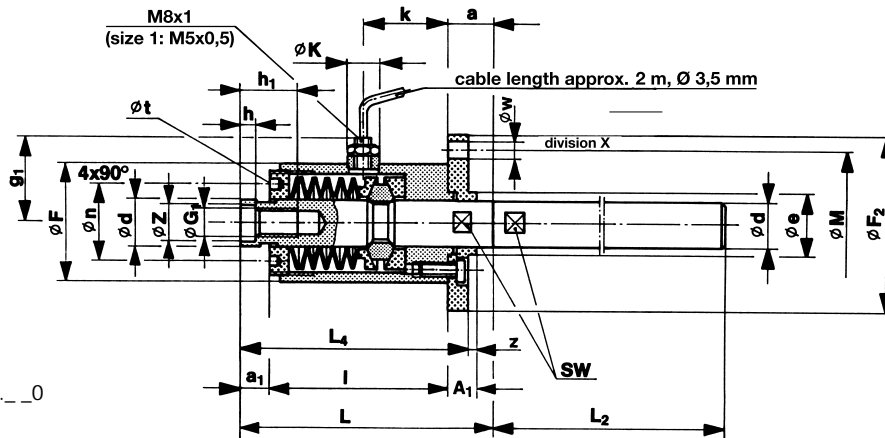

size 1 – 8 Type 322.__0

Technical data

Size	Disengaging forces ¹⁾ F _A [N]			Free stroke ²⁾ H _{1 max} [mm]
	Type 322.4_0	Type 322.5_0	Type 322.6_0	
1	75 – 200	200 – 500	300 – 800	max. 200
2	200 – 500	500 – 800	800 – 2000	max. 300
3	300 – 600	600 – 2000	2000 – 5000	max. 400
4	–	2000 – 6000	6000 – 12000	max. 500
5	3000 – 7500	6000 – 12000	12000 – 30000	max. 600
6	6000 – 12000	12000 – 30000	30000 – 70000	max. 700
7	12000 – 30000	30000 – 70000	70000 – 150000	max. 800
8	30000 – 70000	70000 – 150000	150000 – 300000	max. 1000

Table of dimensions

Size	A ₁	a	a ₁	d _{h9}	e _{f7}	F	F ₂	G ₁	g ₁	h	h ₁	K	k	L
1	8	8	6	10	14	30	42	M 6 x 0,75	43	5	12	15,5	18	52
2	10	12	10	14	18	37	55	M10 x 0,75	41	9	18	15,5	30	75
3	12	15	10	20	25	48	70	M12 x 1,0	47	10	22	15,5	33	95
4	15	20	15	30	35	68	95	M20 x 1,0	57	15	32	15,5	44	130
5	21	32,5	15	40	50	95	128	M24 x 1,5	67	20	42	–	59	190
6	30	35	15	50	60	120	158	M30 x 1,5	76	25	53	–	74	230
7	40	50	25	70	85	160	210	M48 x 2,0	89	35	73	–	114	350
8	55	65	30	100	120	240	316	M75 x 2,0	127	50	103	–	163	460

Size	L ₂	L ₄	I	M	n	t	w	x	Z ^{H7/h7}	z	SW
1	lengths of depend on free stroke in tensile and compressive directions, calculation see pages 18/19		38	36	17	3	3,4	6 x 60°	7	2	9
2		53	46	22	4	5,5	6 x 60°	11	2	13	
3		70	60	31	5	6,6	6 x 60°	13	3	17	
4		95	82	48	6	9	6 x 60°	22	4	27	
5		142,5	112	69	8	11	6 x 60°	28	6	36	
6		180	140	90	8	13,5	6 x 60°	36	8	46	
7		275	186	115	8	17,5	6 x 60°	52	10	65	
8		365	280	170	10	26	6 x 60°	78	15	90	

1) for lower or higher disengaging forces on request re-engaging force = 20 – 25% of the disengaging force
 2) H_{1 max}: free stroke in tensile direction (larger free strokes on request)

We reserve the right to make dimensional and design alterations.

Order example:

To be included when ordering, please state:	size	Type	length of the guide rod
Order number:		3 2 2 . _ _ 0	L ₂ =

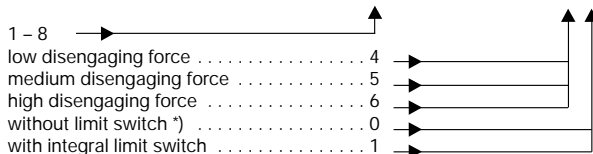

Calculation according to "design of length", see Technical data pages 18/19.

Example: order number 2 / 322.410 / L₂ = 185

*) EAS®-axial without limit switch
 • delivery with bushing (M8 or M5)

Basic element with guide rod and sleeve

Type 312.__0

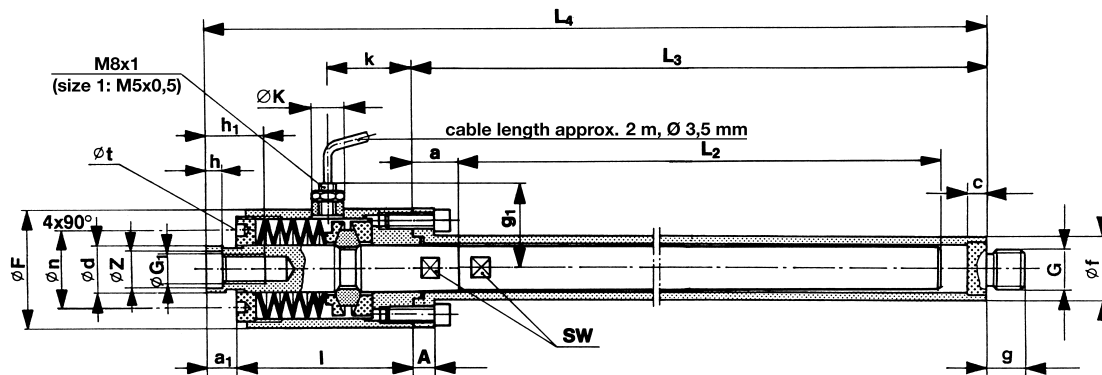

size 1 – 8 Type 312.__0

Technical data

Size	Disengaging forces ¹⁾ F _A [N]			Free stroke ²⁾ H _{1 max} [mm]
	Type 312.4_0	Type 312.5_0	Type 312.6_0	
1	75 – 200	200 – 500	300 – 800	max. 200
2	200 – 500	500 – 800	800 – 2000	max. 300
3	300 – 600	600 – 2000	2000 – 5000	max. 400
4	–	2000 – 6000	6000 – 12000	max. 500
5	3000 – 7500	6000 – 12000	12000 – 30000	max. 600
6	6000 – 12000	12000 – 30000	30000 – 70000	max. 700
7	12000 – 30000	30000 – 70000	70000 – 150000	max. 800
8	30000 – 70000	70000 – 150000	150000 – 300000	max. 1000

Table of dimensions

Size	A	a	a ₁	c	d _{h9}	F	f	G	G ₁	g	g ₁	h	h ₁
1	7	8	6	5	10	30	14	M 8	M 6 x 0,75	10	43	5	12
2	8	12	10	6	14	37	19	M12	M10 x 0,75	15	41	9	18
3	10	15	10	8	20	48	26	M16	M12 x 1,0	20	47	10	22
4	12	20	15	10	30	68	38	M24 x 2	M20 x 1,0	30	57	15	32
5	15	32,5	15	12,5	40	95	55	M30 x 2	M24 x 1,5	35	67	20	42
6	22	35	15	16	50	120	70	M36 x 3	M30 x 1,5	42	76	25	53
7	32	50	25	20	70	160	95	M52 x 3	M48 x 2,0	50	89	35	73
8	44	65	30	26	100	240	130	M64 x 4	M75 x 2,0	60	127	50	103

Size	K	k	L ₂	L ₃	L ₄	l	n	t	Z _{h7} ^{H7}	SW
1	15,5	18				38	17	3	7	9
2	15,5	30	lengths depend			53	22	4	11	13
3	15,5	33	on free stroke			70	31	5	13	17
4	15,5	44	in tensile and compressive			95	48	6	22	27
5	–	59	direction			142,5	69	8	28	36
6	–	74	calculation see			180	90	8	36	46
7	–	114	pages 18/19			275	115	8	52	65
8	–	163				365	170	10	78	90

1) for lower or higher disengaging forces on request
re-engaging force = 20 – 25% of the disengaging force

We reserve the right to make dimensional and design alterations.

2) H_{1 max}: free stroke in tensile direction (larger free strokes on request)

Order example:

To be included when ordering, please state:	size	Type	length of the guide rod	length of the sleeve
Order number:		3 1 2 . _ _ 0	L ₂ =	L ₃ =

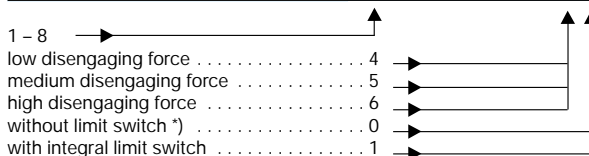

Calculation according to "design of length", see Technical data pages 18/19.

*) EAS[®]-axial without limit switch
• delivery with bushing (M8 or M5)

Example: order number 1 / 312.600 / L₂ = 210 / L₃ = 300

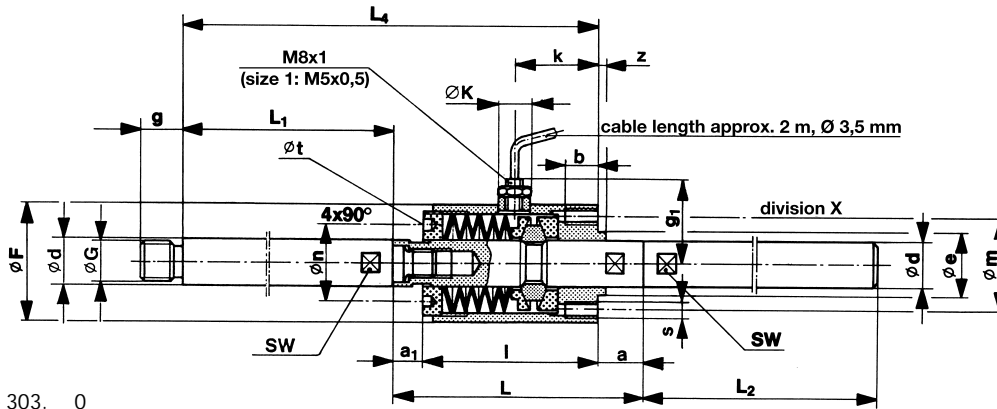

size 1 – 8 Type 303.__0

Technical data

Size	Disengaging forces ¹⁾ F _A [N]			Free stroke ²⁾ H _{1 max} , H _{2 max} [mm]
	Type 303.4_0	Type 303.5_0	Type 303.6_0	
1	75 – 200	200 – 500	300 – 800	max. 200
2	200 – 500	500 – 800	800 – 2000	max. 300
3	300 – 600	600 – 2000	2000 – 5000	max. 400
4	–	2000 – 6000	6000 – 12000	max. 500
5	3000 – 7500	6000 – 12000	12000 – 30000	max. 600
6	6000 – 12000	12000 – 30000	30000 – 70000	max. 700
7	12000 – 30000	30000 – 70000	70000 – 150000	max. 800
8	30000 – 70000	70000 – 150000	150000 – 300000	max. 1000

Table of dimensions

Size	a	a ₁	b	d _{h9}	e _{f7}	F	G	g	g ₁	K	k	L
1	8	6	7	10	14	30	M 8	10	43	15,5	18	52
2	12	10	10	14	18	37	M12	15	41	15,5	30	75
3	15	10	12	20	25	48	M16	20	47	15,5	33	95
4	20	15	15	30	35	68	M24 x 2	30	57	15,5	44	130
5	32,5	15	20	40	50	95	M30 x 2	35	67	–	59	190
6	35	15	22	50	60	120	M36 x 3	42	76	–	74	230
7	50	25	35	70	85	160	M52 x 3	50	89	–	114	350
8	65	30	50	100	120	240	M64 x 4	60	127	–	163	460

Size	L ₁	L ₂	L ₄	l	m	n	s	t	x	z	SW
1	lengths depend			38	22	17	M 3	3	6 x 60°	2	9
2	on free stroke			53	28	22	M 5	4	6 x 60°	2	13
3	in tensile and			70	37	31	M 6	5	6 x 60°	3	17
4	compressive directions,			95	52	48	M 8	6	6 x 60°	4	27
5	calculation			142,5	72	69	M 10	8	6 x 60°	6	36
6	see pages 18/19			180	90	90	M 12	8	6 x 60°	8	46
7				275	130	115	M 16	8	6 x 60°	10	65
8				365	180	170	M 24	10	6 x 60°	15	90

1) for lower or higher disengaging forces on request
re-engaging force = 20 – 25% of the disengaging force

We reserve the right to make dimensional and design alterations.

2) H_{1 max}: free stroke in tensile direction; H_{2 max}: free stroke in compressive direction (larger free strokes on request)

Order example:

To be included when ordering, please state:	size	Type	length of the guide rod	length of the sleeve
Order number:		303.__0	L ₁ =	L ₂ =

- 1 – 8 →
- low disengaging force 4
- medium disengaging force 5
- high disengaging force 6
- without limit switch *) 0
- with integral limit switch 1

Calculation according to "design of length", see Technical data pages 18/19.

*) EAS®-axial without limit switch
• delivery with bushing (M8 or M5)

Example: order number 1 / 303.610 / L₁ = 320 / L₂ = 320

**Exterior flange design with
connecting rod and guide rod**

Type 323.__0

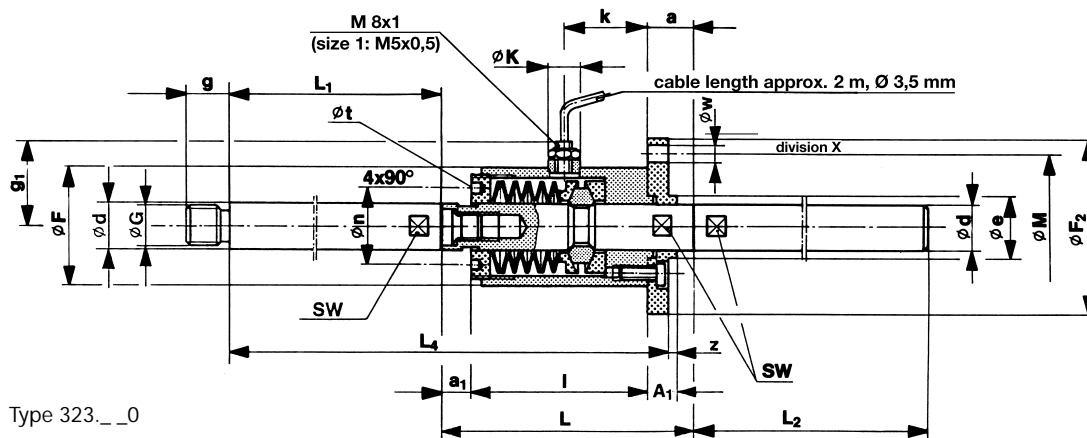

size 1 – 8 Type 323.__0

Technical data

Size	Disengaging forces ¹⁾ F _A [N]			Free stroke ²⁾ H _{1 max} , H _{2 max} [mm]
	Type 323.4_0	Type 323.5_0	Type 323.6_0	
1	75 – 200	200 – 500	300 – 800	max. 200
2	200 – 500	500 – 800	800 – 2000	max. 300
3	300 – 600	600 – 2000	2000 – 5000	max. 400
4	–	2000 – 6000	6000 – 12000	max. 500
5	3000 – 7500	6000 – 12000	12000 – 30000	max. 600
6	6000 – 12000	12000 – 30000	30000 – 70000	max. 700
7	12000 – 30000	30000 – 70000	70000 – 150000	max. 800
8	30000 – 70000	70000 – 150000	150000 – 300000	max. 1000

Table of dimensions

Size	A ₁	a	a ₁	d _{h9}	e _{f7}	F	F ₂	G	g	g ₁	K	k
1	8	8	6	10	14	30	42	M 8	10	43	15,5	18
2	10	12	10	14	18	37	55	M12	15	41	15,5	30
3	12	15	10	20	25	48	70	M16	20	47	15,5	33
4	15	20	15	30	35	68	95	M24 x 2	30	57	15,5	44
5	21	32,5	15	40	50	95	128	M30 x 2	35	67	–	59
6	30	35	15	50	60	120	158	M36 x 3	42	76	–	74
7	40	50	25	70	85	160	210	M52 x 3	50	89	–	114
8	55	65	30	100	120	240	316	M64 x 4	60	127	–	163

Size	L	L ₁	L ₂	L ₄	l	M	n	t	w	x	z	SW
1	52				38	36	17	3	3,4	6 x 60°	2	9
2	75	lengths depend			53	46	22	4	5,5	6 x 60°	2	13
3	95	on free stroke			70	60	31	5	6,6	6 x 60°	3	17
4	130	in tensile and			95	82	48	6	9	6 x 60°	4	27
5	190	compressive directions,			142,5	112	69	8	11	6 x 60°	6	36
6	230	calculation			180	140	90	8	13,5	6 x 60°	8	46
7	350	see pages 18/19			275	186	115	8	17,5	6 x 60°	10	65
8	460				365	280	170	10	26	6 x 60°	15	90

1) for lower or higher disengaging forces on request
re-engaging force = 20 – 25% of the disengaging force

We reserve the right to make dimensional and design alterations.

2) H_{1 max}: free stroke in tensile direction; H_{2 max}: free stroke in compressive direction (larger free strokes on request)

Order example:

To be included when ordering, please state:	size	Type	length of the guide rod	length of the sleeve
Order number:		3 2 3 . _ _ 0	L ₁ =	L ₂ =

- 1 – 8 →
- low disengaging force 4
- medium disengaging force 5
- high disengaging force 6
- without limit switch *) 0
- with integral limit switch 1

Calculation according to "design of length", see Technical data pages 18/19.

*) EAS[®]-axial without limit switch
• delivery with bushing (M8 or M5)

Example: order number 1 / 323.510 / L₁ = 140 / L₂ = 155

Length layout calculation

with indicated free stroke: in tensile direction H_1 / in compressive direction H_2

Disengaging direction free stroke	design			Type	minimum length of the connecting rod L_1 [mm]	minimum length of the guide rod L_2 [mm]	minimum length of the sleeve L_3 [mm]	minimum overall length L_4 [mm] ¹⁾	page
	tension H_1	compression H_2	connecting rod element guide rod/sleeve						
				310.__0			$L_3 = H_2 + a + c + 2$	$L_4 = L_3 + a_1 + l$	8
→				301.__0	$L_1 = H_2 - a_1$			$L_4 = L_1 + a_1 + l$	9
→				321.__0	$L_1 = H_2 - a_1$			$L_4 = L_1 + a_1 + l + A_1 - z$	10
→				311.__0	$L_1 = H_2 - a_1$		$L_3 = H_2 + a + c + 2$	$L_4 = L_1 + L_3 + a_1 + l$	11
←				302.__0		$L_2 = H_1 - a - 2$		$L_4 = a_1 + l$	12
←				322.__0		$L_2 = H_1 - a - 2$		$L_4 = a_1 + l + A_1 - z$	13
←				312.__0		$L_2 = H_1 - a - 2$	$L_3 = H_1 + c$	$L_4 = L_3 + a_1 + l$	14
↔				303.__0	$L_1 = H_2 - a_1$	$L_2 = H_1 - a - 2$		$L_4 = L_1 + a_1 + l$	15
↔				323.__0	$L_1 = H_2 - a_1$	$L_2 = H_1 - a - 2$		$L_4 = L_1 + a_1 + l + A_1 - z$	16
				313.__0	$L_1 = H_2 - a_1$	$L_2 = H_1 - a - 2$	$L_3 = H_1 + H_2 + c$	$L_4 = L_1 + L_3 + a_1 + l$	17

H_1 [mm] free stroke in tensile direction ²⁾

H_2 [mm] free stroke in compressive direction

L_1 [mm] minimum length of the connecting rod to be able to accommodate the free stroke in compressive direction H_2 .

L_2 [mm] minimum length of guide rod to be able to accommodate the free stroke in tensile direction H_1 .

L_3 [mm] minimum sleeve length

L_4 [mm] minimum overall length

Dimensions A_1, a, a_1, c, l, z from dimensional tables

¹⁾ if a larger overall length is required, the sleeve or connecting rod must be correspondingly longer.

²⁾ the max. defined free stroke in tensile direction must not be exceeded otherwise the element is pulled apart.

Calculation example for the length layout

Crank mechanism for the linear operation of a carriage.

Technical data:

mass $m = 40$ kg
 drive speed $n = 150$ rpm
 angular velocity
 $\omega = \frac{n \cdot \pi}{30} = 15,71$ s⁻¹

connecting rod ratio

$$\lambda = \frac{r}{D} = 0,05$$

$$\text{link ratio } i = \frac{C}{B} = 3$$

Dimensions:

$B = 150$ mm $E = 94$ mm
 $C = 450$ mm $L_E = 762$ mm
 $D = 950$ mm $r = 50$ mm

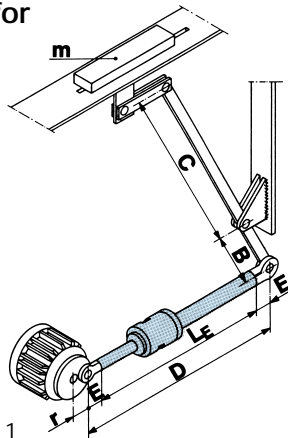

Fig. 1

1. Forces at the carriage and at the EAS®-axial

1.1 max. acceleration of the crank mechanism

$$a_{\max} = \omega^2 \cdot r (1 + \lambda) = 12,96 \text{ m/s}^2$$

1.2 acceleration at the carriage

$$a_{\text{Sch}} = a_K \cdot i = 12,96 \text{ m/s}^2 \cdot 3 = 38,88 \text{ m/s}^2$$

1.3 force at the carriage

$$F_{\text{Sch}} = m \cdot a_{\text{Sch}} = 40 \text{ kg} \cdot 38,88 \text{ m/s}^2 = 1555 \text{ N}$$

1.4 force at the EAS®-axial

$$F_{\text{EAS}} = F_{\text{Sch}} \cdot i = 1555 \text{ N} \cdot 3 = 4665 \text{ N}$$

2. Type and size selection of the EAS®-axial

2.1 level of disengaging force F_A

$$F_A = F_{\text{EAS}} \cdot 1,5 = 4665 \cdot 1,5 = 6998 \text{ N}$$

(factor 1,5 to the consideration of the friction ratios)

2.2 size and type (connecting rod design page 17)

size 4, type 313.600 (disengaging force 6 000 – 12 000 N)

3. Length design (see page 18)

3.1 minimum length of the connecting rod L_1

$$L_1 = H_2 - a_1 = 100 \text{ mm} - 15 \text{ mm} = 85 \text{ mm}$$

with: $H_2 = 2 \cdot r$; a_1 from dimension list page 17

3.2 minimum length of the guide rod L_2

$$L_2 = H_1 - a - 2 = (100 - 20 - 2) \text{ mm} = 78 \text{ mm}$$

with: $H_1 = 2 \cdot r$; a from dimension list page 17

3.3 minimum sleeve length L_3

$$L_3 = H_1 + H_2 + c = (100 + 100 + 10) \text{ mm} = 210 \text{ mm}$$

with: $H_1 = H_2 = 2 \cdot r$; c from dimension list page 17

3.4 minimum overall length L_4

$$L_4 = L_1 + L_3 + a_1 + l = (85 + 210 + 15 + 95) \text{ mm} = 405 \text{ mm}$$

with: L_1 and L_3 from 3.1 und 3.3;
 a_1 and l from dimension list page 17

3.5 The difference ΔL from the required overall length L_E to the minimum overall length L_4 is compensated by extension of the connecting rod and the sleeve.

$$\Delta L = L_E - L_4 = 762 - 405 = 357 \text{ mm}$$

connecting rod length: $L_1 + 178 = 263 \text{ mm}$
 sleeve length: $L_3 + 179 = 389 \text{ mm}$

3.6 Max. permissible length of the connecting rod and the sleeve

connecting rod: $L_1 = H_2 - a_1 = 500 - 15 = 485 \text{ mm}$
 sleeve: $L_3 = H_1 + H_2 + c = 500 + 500 + 10 = 1010 \text{ mm}$
 Connecting rod and sleeve must not become longer than the calculated length with a max. free stroke H_1 and H_2 from dimension list (with size 4: $H_1 = H_2 = 500 \text{ mm}$).

Assembly

The EAS®-axial is supplied assembled ready to be installed. There are special areas milled for the wrenches on the single part for screwing the connecting rod the guide rod and the bolt. The screwed connections are locked with Loctite 242 against self-acting unscrewing. The connection threads of the connecting rod and the sleeve are designed for attaching joint heads according to DIN 648 which are supplied from the works on request.

In case of the design with integrated limit switch the initiator cable must be fixed in such a way that it can't be damaged due to the movement of the EAS®-axial during operation and during disengagement.

Adjustment of the disengaging force

The force at which the EAS®-axial disengages (disengaging forces) is adjusted by adjusting the cup spring pretension.

Adjustment of the size 1 – 4:

The disengaging force is set by turning the adjusting nut with a face wrench. It is increased by clockwise rotation and reduced by anti-clockwise rotation.

Adjustment of the size 5 – 8:

There are 4 or 6 set screws respectively in the adjusting nut which are set to the dimension "a", fig. 3

Locking the set screws by means of hexagon nuts prevents any self acting changing of the adjustment.

The association between "a", fig. 2 and the disengaging force is shown on the adjusting diagram. On request we set the EAS®-axial to the required disengaging force here at the works.

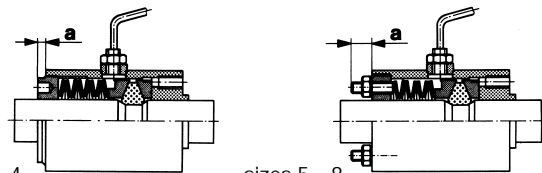

sizes 1 – 4

sizes 5 – 8

Fig. 2

Setting the limit switch (Type PNP-opener)

The EAS®-axial with integrated limit switch gives a signal during disengagement (overload) which can be used to switch off the drive. The limit switch is fitted and set at the works.

Fitting and adjusting:

- screw initiator into the housing until it is damped
- move it slowly backwards until the switching condition is changed again (undamped)
- continue turning by approx. 45° (for size 1 90°) and mark this setting
- lock initiator with a hexagon nut M8x1 (size 1: M5x0,5) carefully (tightening torque: M5 = 1,5 Nm; M8 = 4,5 Nm). (Absolutely remove screw play when locking). The thread of the initiator must not be damaged.

After setting, the initiator cable must be attached at the EAS®-axial in such a way that it cannot be damaged during operation (a strain relief is to be attached).

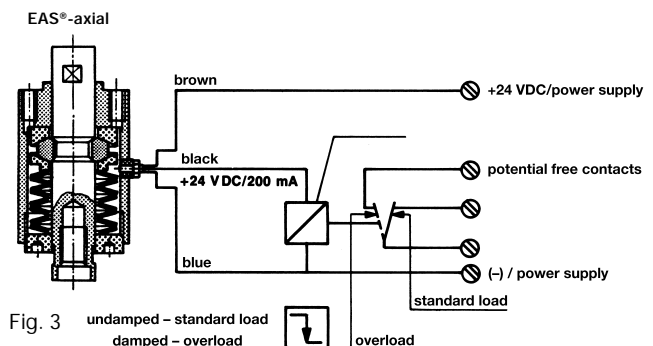

Fig. 3 undamped – standard load
 damped – overload
 overloaded

Maintenance

The EAS®-axial is maintenance-free. It is completely sealed, grease filled and lubricated for life. Special maintenance may only become necessary where there is a considerable amount of dust and dirt. If such extreme ambient conditions are to be expected with the application, we request you to advise or contact our works.

Delivery Programme



Safety clutches/ torque limiters

- ❑ **EAS®-Compact®/EAS®-NC**
Positive, absolutely backlash-free torque limiter
- ❑ **EAS®-smartic®**
Economic torque limiters with fast assembly
- ❑ **EAS®-element clutch/EAS®-elements**
Load disconnecting protection for high torques
- ❑ **EAS®-axial**
Exact limitation of tensile and compressive forces
- ❑ **EAS®-Sp/EAS®-Sm/EAS®-Zr**
Residual torque free disconnecting torque limiter with ON/OFF function
- ❑ **ROBA®-slip hubs**
Load holding, friction type torque limiting clutch
- ❑ **ROBA®-contitorque**
Magnetic continuous slip clutch

Shaft couplings

- ❑ **smartflex®**
Perfect precision coupling for servo and stepper motors
- ❑ **ROBA®-ES**
Backlash-free and damping of vibration critical drives
- ❑ **ROBA®-DS/ROBA®-D**
Backlash-free, torsionally rigid all-steel coupling
- ❑ **EAS®-control-DS**
Low cost torque-measuring coupling

Electromagnetic brakes/clutches

- ❑ **ROBA-stop® Standard**
Multi-functionally all-round safety brake
- ❑ **ROBA-stop®-M motor brakes**
Robust, cost effective motor brake
- ❑ **ROBA-stop®-S**
Waterproof, robust monobloc brake
- ❑ **ROBA-stop®-Z/ROBA-stop®-silenzio®**
Double security elevator brake
- ❑ **ROBA®-diskstop®**
Compact quiet disk brake
- ❑ **ROBA®-topstop®**
Brake systems for gravity loaded axes
- ❑ **ROBA®-linearstop**
Backlash-free brake system for linear motor axes
- ❑ **ROBATIC®/ROBA®-quick/ROBA®-takt**
Energise to engage electromagnetic pole face clutches and brakes, CBU

DC drives

- ❑ **tendo®-PM**
Permanent-magnet D.C. motors
- ❑ **tendo®-SC**
1 and 4 Q transistor controllers

